



ASI-T-570GA3T2/D

Item	Contents	Unit
Size	5.7	inch
Resolution	640(RGB) x 480	/
Technology type	a-Si TFT	/
Interface	TTL	
Color depth	262K	
Pixel pitch	0.180x0.180	mm
Pixel Configuration	R.G.B. Vertical Stripe	
Outline Dimension (W x H x D)	144.00x 104.60x12.30	mm
Active Area	115.20 x 86.40	mm
Display Mode	Transmissive, Normally White	/
Backlight Type	LEDs	/



ASI-T-570GA3T2/D

Record of Revision

Date	Revision No.	Summary
2010-09-14	1.0	Rev 1.0 was issued



ASI-T-570GA3T2/D

1. Scope

This data sheet is to introduce the specification of ASI-T-570GA3T2/D active matrix TFT module. It is composed of a color TFT-LCD panel, driver ICs, FPC Capacitive touch panel and a backlight unit. The 5.7" display area contains 640(RGB) x 480 pixels.

2. Application

Digital equipments which need color display, POS, mobile navigator/video systems.

3. General Information

Item	Contents	Unit
Size	5.7	inch
Resolution	640(RGB) x 480	/
Technology type	a-Si TFT	/
Interface	TTL	
Color depth	262K	
Pixel pitch	0.180x0.180	mm
Pixel Configuration	R.G.B. Vertical Stripe	
Outline Dimension (W x H x D)	144.00x 104.60x12.30	mm
Active Area	115.20 x 86.40	mm
Display Mode	Transmissive, Normally White	/
Backlight Type	LEDs	/



ASI-T-570GA3T2/D

5. Interface signals

5.1 CN1 pin assignment

No	Symbol	I/O	Description	Remarks
1	GND	P	Ground	
2	CK	I	Dot clock. Latch data at falling edge of CK.	
3	Hsync	I	Horizontal sync signal in SYNC mode. Pull low or floating when DE mode.	
4	Vsync	I	Vertical sync signal in SYNC mode. Pull low or floating when DE mode.	
5	GND	P	Ground	
6	R0	I	Red data (LSB)	
7	R1	I	Red data	
8	R2	I	Red data	
9	R3	I	Red data	
10	R4	I	Red data	
11	R5	I	Red data (MSB)	
12	GND	P	Ground	
13	G0	I	Green data(LSB)	
14	G1	I	Green data	
15	G2	I	Green data	
16	G3	I	Green data	
17	G4	I	Green data	
18	G5	I	Green data(MSB)	
19	GND	P	Ground	
20	B0	I	Blue data(LSB)	
21	B1	I	Blue data	
22	B2	I	Blue data	
23	B3	I	Blue data	
24	B4	I	Blue data	
25	B5	I	Blue data(MSB)	
26	GND	P	Ground	
27	ENAB	I	Data enable signal in DE mode. This pin must pull high when SYNC mode.	
28	VCC	P	Power supply	
29	VCC	P	Power supply	
30	R/L	I	Set horizontal scan direction: Low/NC: left to right; High: right to left	
31	U/D	I	Set vertical scan direction: High/NC: up to down; Low: down to up	
32	NC	-	No connection	
33	GND	P	Ground	

Connector type: 089H33-000100-G2-R (STARCONN)



ASI-T-570GA3T2/D

5.2 CN2 pin assignment (Backlight interface)

No	Symbol	Description	Comment
1	AN1	LED Anode Terminal	Red
2	AN2	LED Anode Terminal	Red
3	AN3	LED Anode Terminal	Red
4	CA1	LED Cathode Terminal	White
5	CA2	LED Cathode Terminal	Blue
6	CA3	LED Cathode Terminal	Black

Connector type: SHLP-06V-S-B (JST)

Matching Connector type: SM06B-SHLS-TF (JST)

5.3 CN3 TP signal interface

No	Symbol	Description
1	VSS	GROUND
2	VDD	POWER SUPPLY VOLTAGE
3	SCL (SSEL)	I2C CLOCK INPUT (ACTIVE LOW SELECT SIGNAL)
4	NC (SCK)	NC (SERIAL DATA CLOCK)
5	SDA (MOSI)	I2C DATA INPUT AND OUTPUT (DATA LINE FROM MASTER TO SLAVE)
6	NC (MISO)	NC (DATA LINE FROM SLAVE TO MASTER)
7	/RST	EXTERNAL RESET, LOW IS ACTIVE
8	/WAKE	EXTERNAL INTERRUPT FROM THE HOST
9	/INT	EXTERNAL INTERRUPT TO THE HOST
10	VSS	GROUND

Matching Connector type: KYOCERA : 04 6240 010 SERIES



ASI-T-570GA3T2/D

6. Absolute maximum Ratings

6.1. Electrical Absolute max. ratings

Parameter	Symbol	MIN	MAX	Unit	Remark
Power Voltage	VCC	-0.5	5.0	V	
Input voltage	R0~R5, G0~G5, B0~B5, CK, Hsync, Vsync, Enable, R/L, U/D	-0.5	5.0	V	

6.2 Environment Conditions

Item	Symbol	MIN	MAX	Unit	Remark
Operating Temperature	TOPR	-30	85	°C	
Storage Temperature	TSTG	-30	85	°C	



ASI-T-570GA3T2/D

7. Electrical Specifications

7.1 Electrical characteristics

GND=0V, Ta=25°C

Item	Symbol	MIN	TYP	MAX	Unit	Remark
Supply Voltage	VCC	3.0	3.3	3.6	V	
Permissible input ripple voltage	Vr	-	-	100	mVp-p	Vcc=3.3V
Input Signal Voltage	VIL	0	-	0.3*VCC	V	
	VIH	0.7* IOVCC	-	VCC	V	

7.2 LED Backlight

Ta=25°C

Item	Symbol	MIN	TYP	MAX	Unit	Remark
Series 1 Forward Current	I1	-	25	-	mA	For each one
Series 2 Forward Current	I2	-	25	--	mA	
Series 3 Forward Current	I3	-	25		mA	
Forward Voltage	VF	19.95	-	25.9	V	
Backlight power	W _{BL}		1732.5		mW	Note
Life time		25,000	50,000		Hrs	

Note: Operating life means brightness goes down to 50% initial brightness.
 Typical operating life time is estimated data.

LED connection of backlight

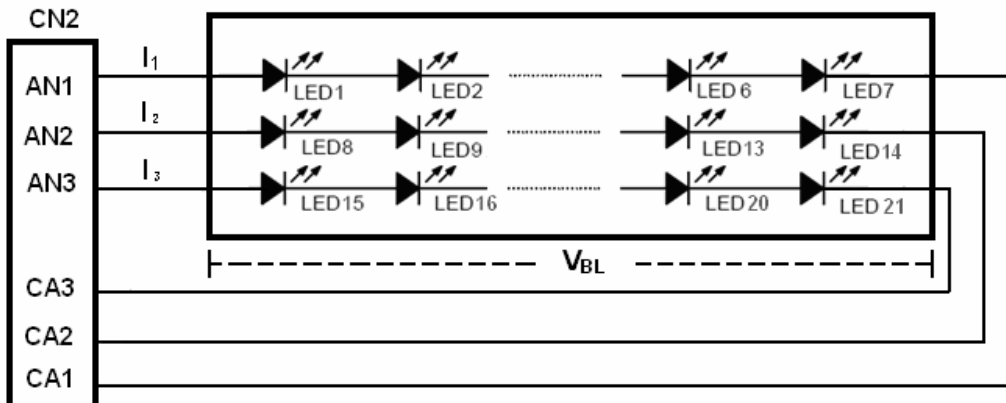

7.3 Schematic of LCD module system

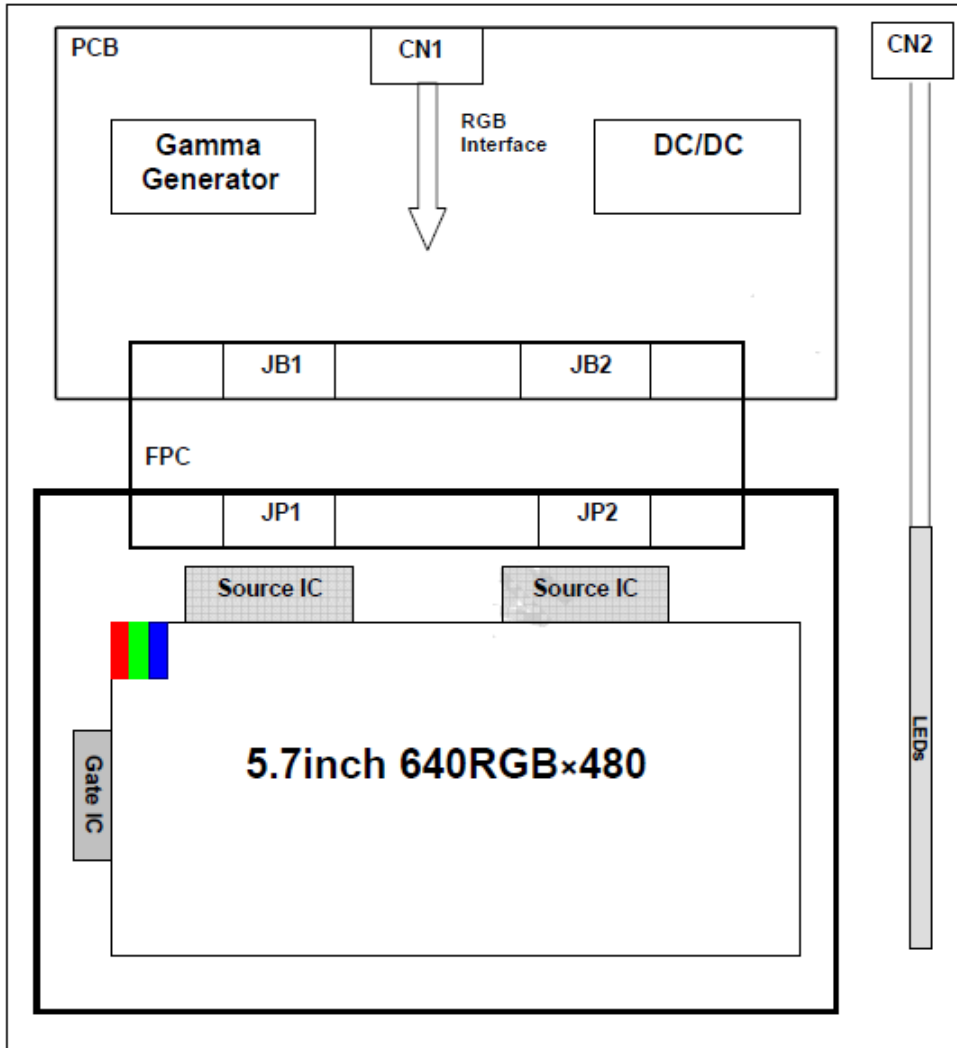



8. Command/AC Timing

8.1 SYNC mode

Parameter	Symbol	Symbol	Min	Typ	Max	Unit
CK	Dotclk frequency	Fclk	24.8	25.2	34.2	MHz
	Dotclk cycle	Tclk	29.24	39.68	40.32	ns
Hsync	Horizontal display area	Thd	640	640	640	Tclk
	1 horizontal line	Th	800	800	1000	Tclk
	Hsync pulse width	Thpw	1	-	-	Tclk
	Horizontal blank	Thb	144	144	144 Tclk	
	Horizontal front porch	Thfp	16	16	216	Tclk
Vsync	Frame rate	-	-	60	-	Hz
	Vertical display area	Tvd	480	480	480	Th
	Vsync period time	Tv	516	525	570	Th
	Vsync pulse width	Tvpw	1	-	-	Th
	Vsync blank	Tvb	35	35	35	Th
	Vsync front porch	Tvfp	1	10	55	Th

8.2 DE mode

Description		Symbol	Min	Typ	Max	Unit
CK	Dot clock frequency	Fclk	24.8	25.2	34.2	MHz
Horizontal section	Horizontal total	Th	800	800	1000	Tclk
	H Total blank	Thb+Thfp	160	160	360	Tclk
	Valid Data Width	Thd	640	640	640	Tclk
Vertical section	Frame rate	-	-	60	-	Hz
	Vertical total	Tv	516	525	570	Th
	V total blank	Tvb+Tvfp	36	45	90	Th
	Valid Data Width	Tvd	480	480	480	Th

Note: The LCM could auto-detect which mode is working.

8.3 Timing diagram

8.3.1 vertical input timing

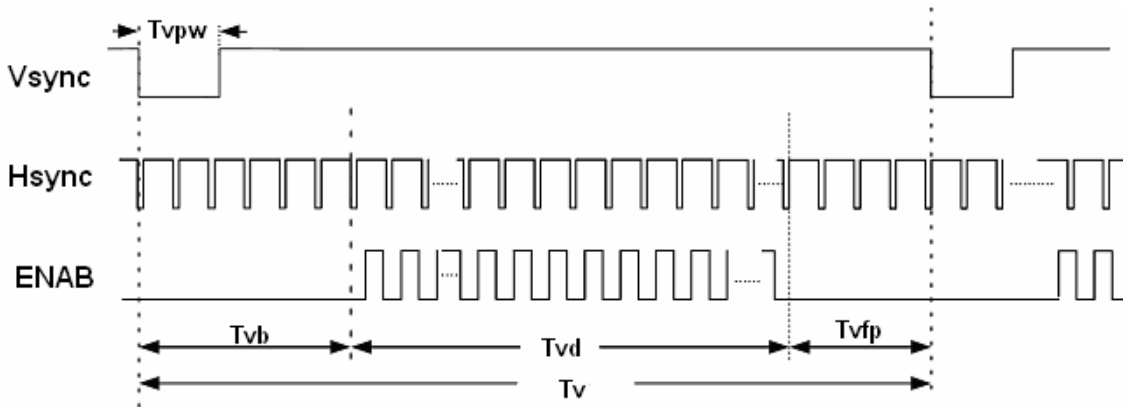

8.3.2 Horizontal Input Timing

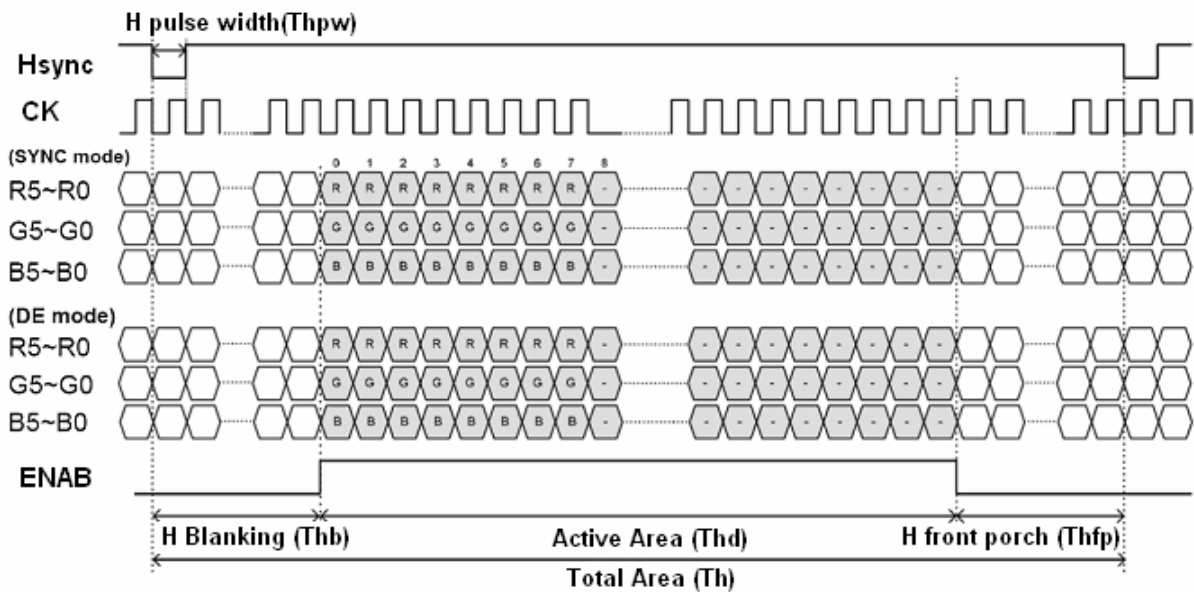



ASI-T-570GA3T2/D

8.4 AC input characteristics

Parameter	Symbol	Min	Typ	Max	Unit	Conditions
CK pulse duty	Tcwh	40%	50%	60%	Tclk	
Vsync setup time	Tvst	8	-	-	ns	
Vsync hold time	Tvhd	8	-	-	ns	
Hsync setup time	Thst	8	-	-	ns	
Hsync hold time	Thhd	8	-	-	ns	
Data setup time	Tdsu	8	-	-	ns	Rn, Gn, Bn to Dotclk
Data hold time	Tdhd	8	-	-	ns	Rn, Gn, Bn to Dotclk
ENAB setup time	Tesu	8			ns	

AC input characteristics

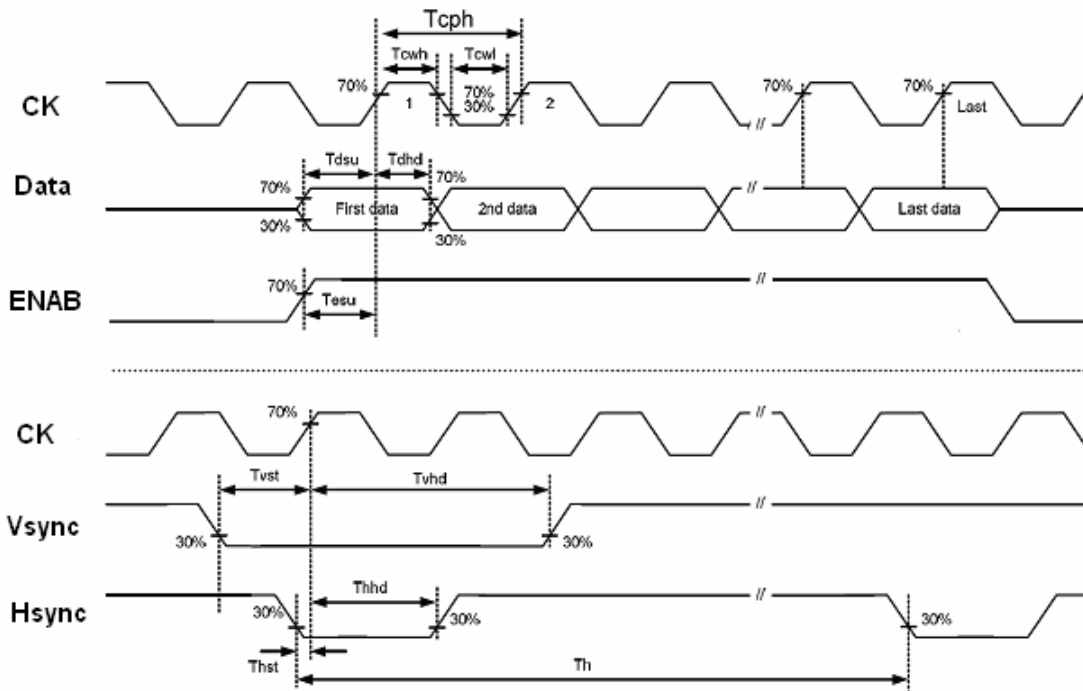



ASI-T-570GA3T2/D

8.5 POWER ON/OFF SEQUENCE

Item	Symbol	Min	Typ	Max	Unit	Remark
VCC 3.0V to signal starting	Tp1	5	-	50	ms	
Signal starting to backlight on	Tp2	50	-	-	ms	
Signal off to VCC 3.0V	Tp3	0	-	50	ms	
Backlight off to signal off	Tp4	50	-	-	ms	

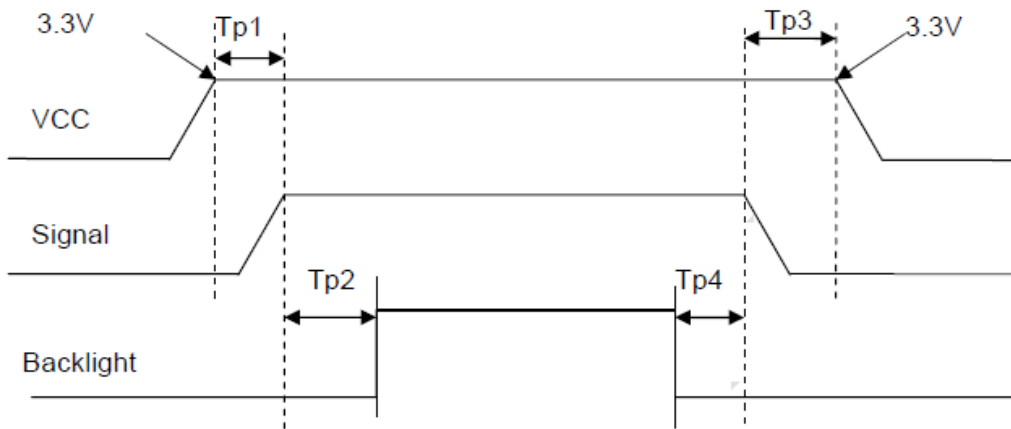



ASI-T-570GA3T2/D

9 Optical Specification

Item	Symbol	Condition	Min	Typ.	Max.	Unit	Remark	
Contrast Ratio	CR	$\theta=0^\circ$	400	500	-		Note1 Note2	
Response Time	Ton/ Toff	25°C	-	40	-	ms	Note1 Note3	
View Angles	θT	$CR \geq 10$	60	70	-	Degree	Note 4	
	θB		50	60	-			
	θL		60	70	-			
	θR		60	70	-			
Chromaticity	White	Brightness is on	Typ-0.05	0.302	Typ+0.05		Note5, Note1	
				y				0.329
	Red			x				0.598
				y				0.342
	Green			x				0.334
				y				0.585
	Blue			x				0.142
				y				0.102
NSTC	S		-	50		%	Note 5	
Luminance	L		280	360	-	cd/m ²	Note1 Note6	
Uniformity	U		75	80	-	%	Note1 Note7	

Note 1: Definition of optical measurement system.

Temperature = 25°C(±3°C)

LED back-light: ON, Environment brightness < 150 lx

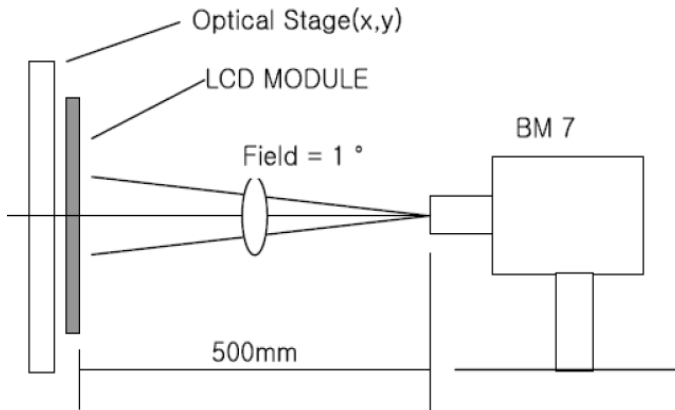

Note 2: Contrast ratio is defined as follow:

$$\text{Contrast Ratio} = \frac{\text{Surface Luminance with all white pixels}}{\text{Surface Luminance with all black pixels}}$$

Note 3: Response time is defined as follow:

Response time is the time required for the display to transition from black to white (Rise Time, T_r) and from white to black(Decay Time, T_f).

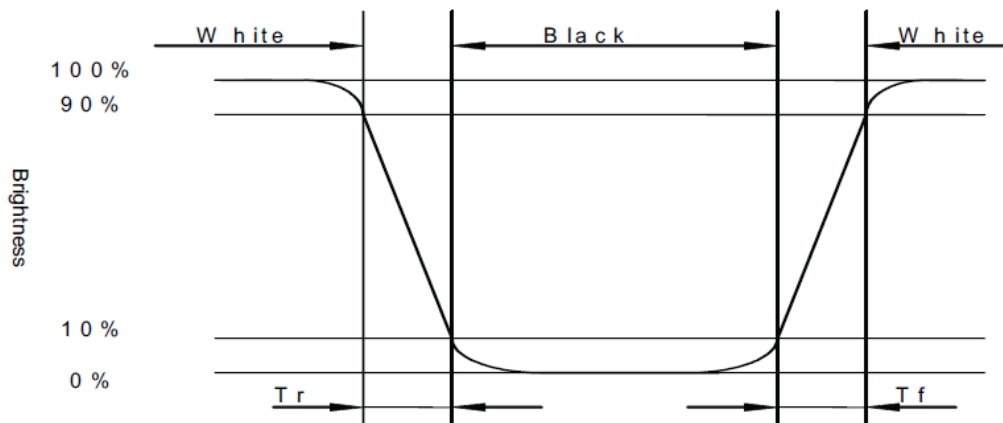

Note 4: Viewing angle range is defined as follow:

Viewing angle is measured at the center point of the LCD.

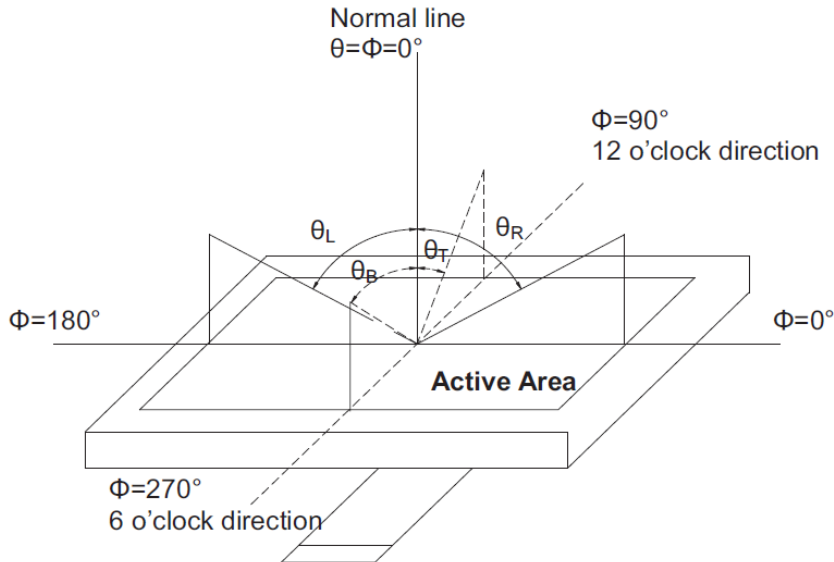

Note 5: Color chromaticity is defined as follow: (CIE1931)

Color coordinates measured at center point of LCD.

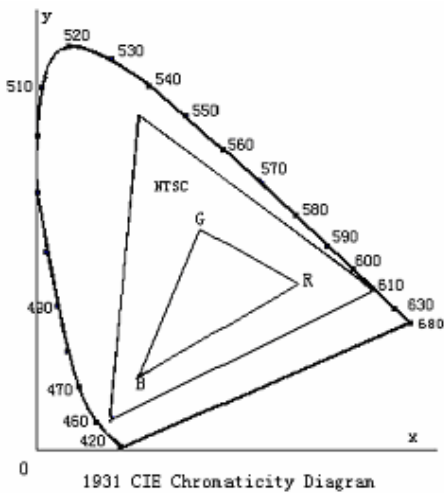

$$S = \frac{\text{area of RGB triangle}}{\text{area of NTSC triangle}} \times 100\%$$

Note 6: Luminance is defined as follow:

Luminance is defined as the brightness of all pixels “White” at the center of display area on optimum contrast



ASI-T-570GA3T2/D

Note 7: Definition of Luminance Uniformity

Active area is divided into 9 measuring areas (Refer Fig. 2). Every measuring point is placed at the center of each measuring area.

Luminance Uniformity (U) = L_{min} / L_{max}

L-----Active area length W----- Active area width

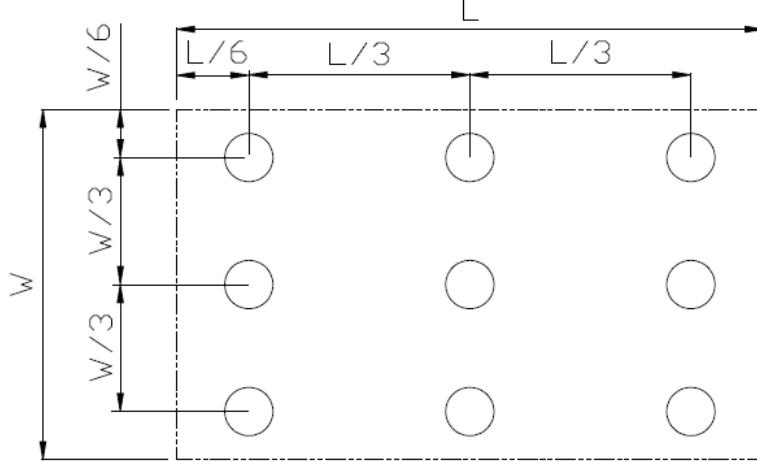



ASI-T-570GA3T2/D

10 Environmental / Reliability Tests

No	Test Item	Condition	Judgment criteria
1	High Temp Operation	Ts=+85°C, 120hrs	Per table in below
2	Low Temp Operation	Ta=-30°C, 120hrs	Per table in below
3	High Temp Storage	Ta=+85°C, 120hrs	Per table in below
4	Low Temp Storage	Ta=-30°C, 120hrs	Per table in below
5	High Temp & High Humidity Storage	Ta=+40°C, 90% RH 120 hours	Per table in below (polarizer discoloration is excluded)
6	Thermal Shock (Non-operation)	-30°C 30 min~+80°C 30 min, Change time:5min, 10 Cycles	Per table in below
7	ESD (Operation)	C=150pF, R=330Ω , 5points/panel Air:±8KV, 5times; Contact:±4KV, 5 times;	Per table in below
8	Vibration (Non-operation)	Frequency range:10~55Hz, Stroke:1.5mm Sweep:10Hz~55Hz~10Hz 2 hours for each direction of X.Y.Z.	Per table in below
9	Shock (Non-operation)	60G 6ms, ±X,±Y,±Z 3times, for each direction	Per table in below
10	Package Drop Test	Height:80 cm, 1 corner, 3 edges, 6 surfaces	Per table in below

INSPECTION	CRITERION(after test)
Appearance	No Crack on the FPC, on the LCD Panel
Alignment of LCD Panel	No Bubbles in the LCD Panel No other Defects of Alignment in Active area
Electrical current	Within device specifications
Function / Display	No Broken Circuit, No Short Circuit or No Black line No Other Defects of Display

11 Precautions for Use of LCD Modules

11.1 Safety

The liquid crystal in the LCD is poisonous. Do not put it in your mouth. If the liquid crystal touches your skin or clothes, wash it off immediately using soap and water.

11.2 Handling

- A. The LCD and touch panel is made of plate glass. Do not subject the panel to mechanical shock or to excessive force on its surface.
- B. Do not handle the product by holding the flexible pattern portion in order to assure the reliability
- C. Transparency is an important factor for the touch panel. Please wear clear finger sacks, gloves and mask to protect the touch panel from finger print or stain and also hold the portion outside the view area when handling the touch panel.
- D. Provide a space so that the panel does not come into contact with other components.
- E. To protect the product from external force, put a covering lens (acrylic board or similar board) and keep an appropriate gap between them.
- F. Transparent electrodes may be disconnected if the panel is used under environmental conditions where dew condensation occurs.
- G. Property of semiconductor devices may be affected when they are exposed to light, possibly resulting in IC malfunctions.
- H. To prevent such IC malfunctions, your design and mounting layout shall be done in the way that the IC is not exposed to light in actual use.

11.3 Static Electricity

- A. Ground soldering iron tips, tools and testers when they are in operation.
- B. Ground your body when handling the products.
- C. Power on the LCD module before applying the voltage to the input terminals.
- D. Do not apply voltage which exceeds the absolute maximum rating.
- E. Store the products in an anti-electrostatic bag or container.

11.4 Storage

- A. Store the products in a dark place at $+25^{\circ}\text{C} \pm 10^{\circ}\text{C}$ with low humidity (40% RH to 60% RH). Don't expose to sunlight or fluorescent light.
- B. Storage in a clean environment, free from dust, active gas, and solvent.

11.5 Cleaning

- A. Do not wipe the touch panel with dry cloth, as it may cause scratch.
- B. Wipe off the stain on the product by using soft cloth moistened with ethanol. Do not allow ethanol to get in between the upper film and the bottom glass. It may cause peeling issue or defective operation. Do not use any organic solvent or detergent other than ethanol.

11.6 Cautions for installing and assembling

Bezel edge must be positioned in the area between the Active area and View area. The bezel may press the touch screen and cause activation if the edge touches the active area. A gap of approximately 0.5mm is needed between the bezel and the top electrode. It may cause unexpected activation if the gap is too narrow. There is a tolerance of 0.2 to 0.3mm for the outside dimensions of the touch panel and tail. A gap must be made to absorb the tolerance in the case and connector.

