



ASI-T-500GA2AN/D

Item	Contents	Unit
Size	5.0	inch
Resolution	640(RGB) x 480	/
Technology type	a-Si TFT	/
Interface	RGB	
Pixel pitch (W x H)	0.053x0.159	mm
Pixel Configuration	R.G.B. Vertical Stripe	
Outline Dimension (W x H x D)	117.65x 88.43x5.7	mm
Active Area(W x H)	101.57 x 76.18	mm
Display Mode	Transmissive, Normally white	/
Backlight Type	LED	/



Record of Revision

Date	Revision No.	Summary
2013-05-17	1.0	Rev 1.0 was issued

1. Scope

This data sheet is to introduce the specification of ASI-T-500GA2AN/D active matrix TFT module. It is composed of a color TFT-LCD panel, driver ICs, FPC and a backlight unit. The 5.0'' display area contains 640(RGB) x 480 pixels.

2. Application

Digital equipments which need color display, mobile navigator/video systems.

3. General Information

Item	Contents	Unit
Size	5.0	inch
Resolution	640(RGB) x 480	/
Technology type	a-Si TFT	/
Interface	RGB	
Pixel pitch (W x H)	0.053x0.159	mm
Pixel Configuration	R.G.B. Vertical Stripe	
Outline Dimension (W x H x D)	117.65x 88.43x5.7	mm
Active Area(W x H)	101.57 x 76.18	mm
Display Mode	Transmissive, Normally white	/
Backlight Type	LED	/

4. Outline Drawing

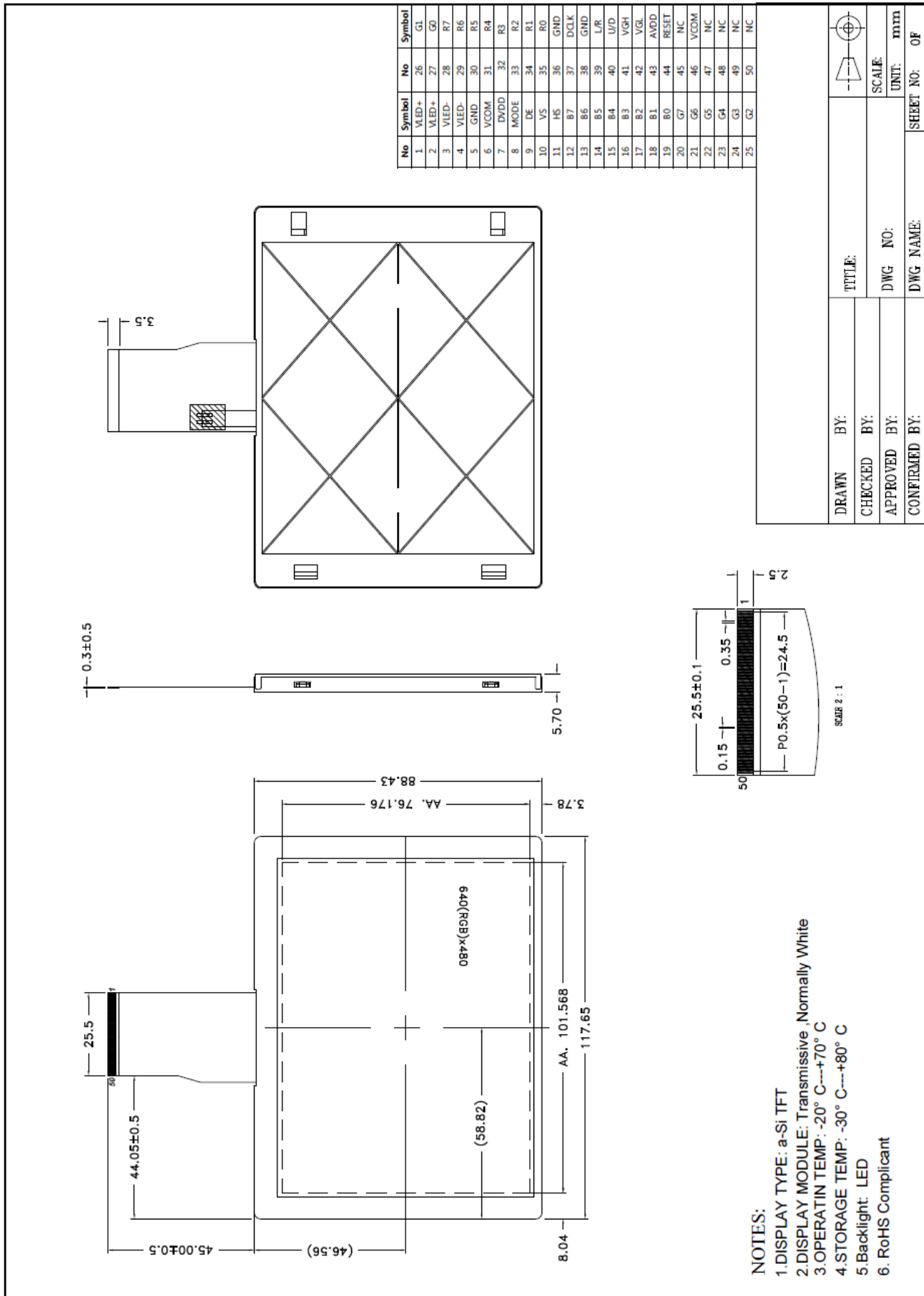

5. Interface signals

Pin No.	Symbol	I/O	Function	Remark
1	VLED+	P	Power for LED Circuit	
2	VLED+	P	Power for LED Circuit	
3	VLED-	P	Power for LED Circuit	
4	VLED-	P	Power for LED Circuit	
5	GND	P	Power ground	
6	VCOM	I	VCOM input	
7	DVDD	P	Power for Digital Circuit	
8	MODE	I	DE or HV mode control	Note 1
9	DE	I	Data Enable	
10	VS	I	Vsync signal input	
11	HS	I	Hsync signal input	
12	B7	I	Blue data input (MSB)	
13	B6	I	Blue data input	
14	B5	I	Blue data input	
15	B4	I	Blue data input	
16	B3	I	Blue data input	
17	B2	I	Blue data input	
18	B1	I	Blue data input	
19	B0	I	Blue data input(LSB)	
20	G7	I	Green data input(MSB)	
21	G6	I	Green data input	
22	G5	I	Green data input	
23	G4	I	Green data input	
24	G3	I	Green data input	
25	G2	I	Green data input	
26	G1	I	Green data input	
27	G0	I	Green data input(LSB)	
28	R7	I	Red data input(MSB)	
29	R6	I	Red data input	
30	R5	I	Red data input	
31	R4	I	Red data input	
32	R3	I	Red data input	
33	R2	I	Red data input	
34	R1	I	Red data input	
35	R0	I	Red data input(LSB)	
36	GND	P	Power ground	
37	DCLK	I	Sample clock	
38	GND	P	Power ground	
39	L/R	I	Select left to right scanning direction	Note 2

40	U/D	I	Select up or down scanning direction	Note 2
41	VGH	I	Positive power for scan driver	
42	VGL	I	Negative power for scan driver	
43	AVDD	P	Power for Analog Circuit	
44	RESET	I	Reset	
45	NC	-	No Connection	
46	VCOM	I	VCOM input	
47	NC	-	No Connection	
48	NC	-	No Connection	
49	NC	-	No Connection	
50	NC	-	No Connection	

The recommended connector: FH12S-50S-0.5SH(Hirose).

Note: I: input, O: output, P: Power

Note 1: DE Mode, Mode="H", HS floating and VS floating

HV Mode, Mode="L" and DE floating

2 Selection of scanning mode

U/D	L/R	Function
DVDD	DVDD	Up to down, left to right
GND	DVDD	Down to up, left to right
DVDD	GND	Up to down, right to left
GND	GND	Down to up, right to left

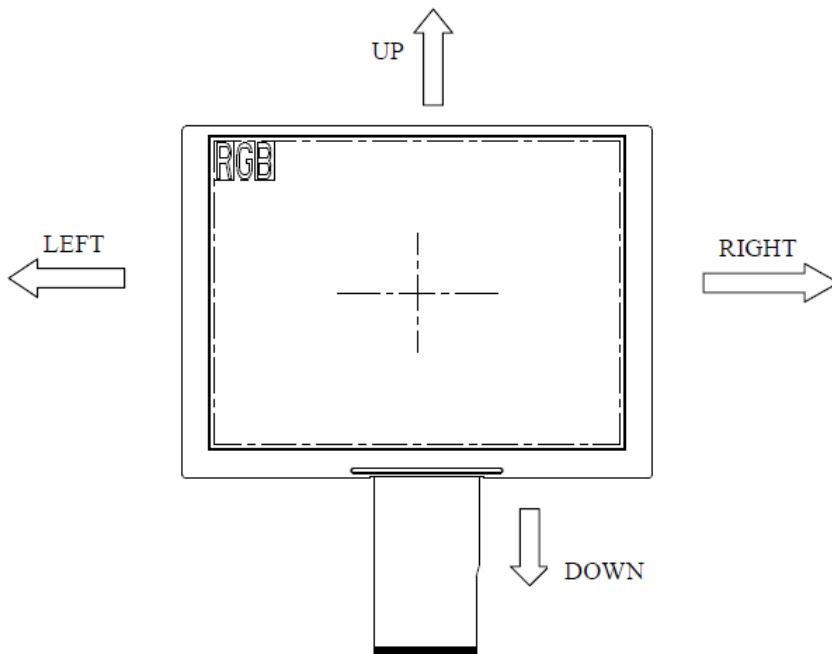

6. Absolute maximum Ratings

6.1. Electrical Absolute max. ratings

Parameter	Symbol	MIN	MAX	Unit	Remark
Power Supply Voltage	DVDD	-0.3	5.0	V	
	AVDD	6.5	13.5	V	
	V _{GH}	-0.3	42	V	
	V _{GL}	-20.00	0.3	V	
	V _{GH} -V _{GL}	-	40.0	V	

6.2. Environment Conditions

Item	Symbol	MIN	MAX	Unit	Remark
Operating Temperature	TOPR	-20	70	°C	
Storage Temperature	TSTG	-30	80	°C	

7. Electrical Specifications

7.1 Electrical characteristics

GND=0V, Ta=25°C

Item	Symbol	MIN	TYP	MAX	Unit	Remark
Power Supply voltage	DVDD	3.0	3.3	3.6	V	
	AVDD	10.2	10.4	10.6	V	
	VGH	16.7	17.0	17.3	V	
	VGL	-7.3	-7.0	-6.7	V	
Input signal voltage	VCOM	3.2	3.5	3.8	V	Note 1
Input Logic Voltage	VIL	0	--	0.3DVDD	V	
	VIH	0.7DVDD	--	DVDD	V	

Note 1: Typical Vcom is only a reference value, it must be optimized according to each LCM, please use VR and base on below application circuit.

Note 2: Be sure to apply GND, DVDD, and VGL, to the LCD first, and then apply VGH.

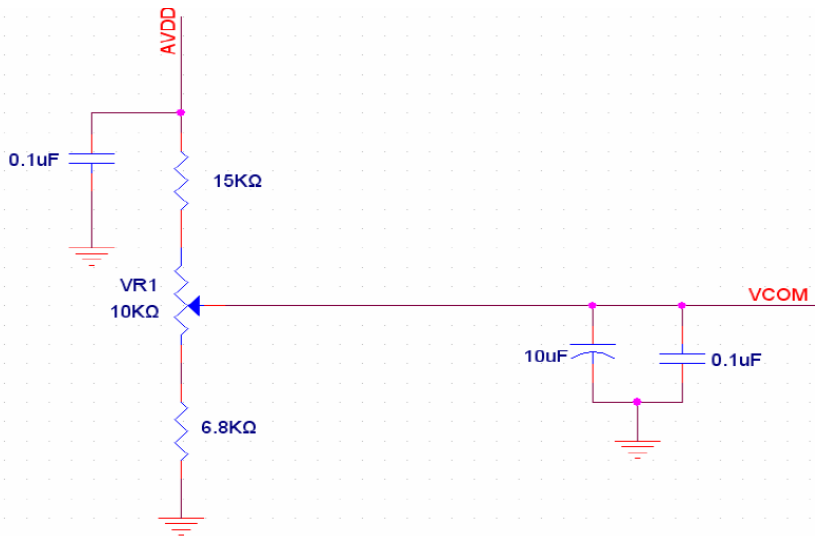

7.2 LED Backlight

Ta=25°C

Item	Symbol	MIN	TYP	MAX	Unit	Remark
Forward Current	IF	--	60	--	mA	
Forward Voltage	VF	14.6	15.5	16.4	V	Note 1

Note 1: The Voltage for LED Backlight is defined at Ta=25°C and IL =60mA.

8. Command/AC Timing

8.1 Input/output timing

Parameter	Symbol	MIN.	TYP.	MAX.	Unit	Note
PXLCLK clock time	Tclk	12.3	13.5	-	ns	1 Tclk
PXLCLK pulse duty	Tcwh	40	50	60	%	Tclk
DATA set-up time	Tdsu	5	-	-	ns	DATA to PXLCLK
DATA hold time	Tdhd	5	-	-	ns	DATA to PXLCLK
DE setup time	Tesu	5	-	-	ns	DE to PXLCLK
VSYNC setup time	Tvst	5	-	-	ns	
VSYNC hold time	Tvhd	5	-	-	ns	
HSYNC setup time	Thst	5	-	-	ns	
HSYNC hold time	Thhd	5	-	-	ns	
HSYNC period time	Th	22.91	-	-	us	
HSYNC width	Thwh	1	-	-	Tclk	
VSYNC width	Tvwh	1	-	-	Th	

Input Timing Limitation of DE Mode

Parameter	MIN.	TYP.	MAX.	Unit	Note
THC	40	160	480	tclk	
THD	640	640	640	tclk	
TH	688	800	1100	tclk	1TH=1line
TVC	5	45	220	Line	
TVD	480	480	480	line	
TV	485	525	700	line	1TV=1field

Input Timing Limitation of HV Mode

Parameter	MIN.	TYP.	MAX.	Unit	Note
Thwh	-	4	-	tclk	
Thbp	-	42	-	tclk	
Thfp	-	114	-	tclk	
THD	-	640	-	tclk	
TH	-	800	-	line	
Tvwh	-	3	-	line	
Tvbp	-	31	-	line	
Tvfp	-	11	-	line	
TVD	-	480	-	line	
TV	-	525	-	line	1TV=1field

8.2 Timing Diagram

Clock and Data Input Timing Diagram

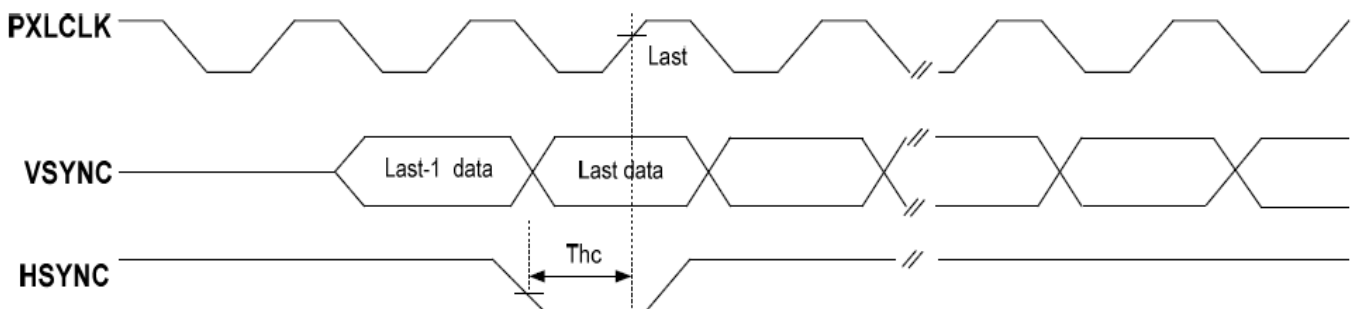
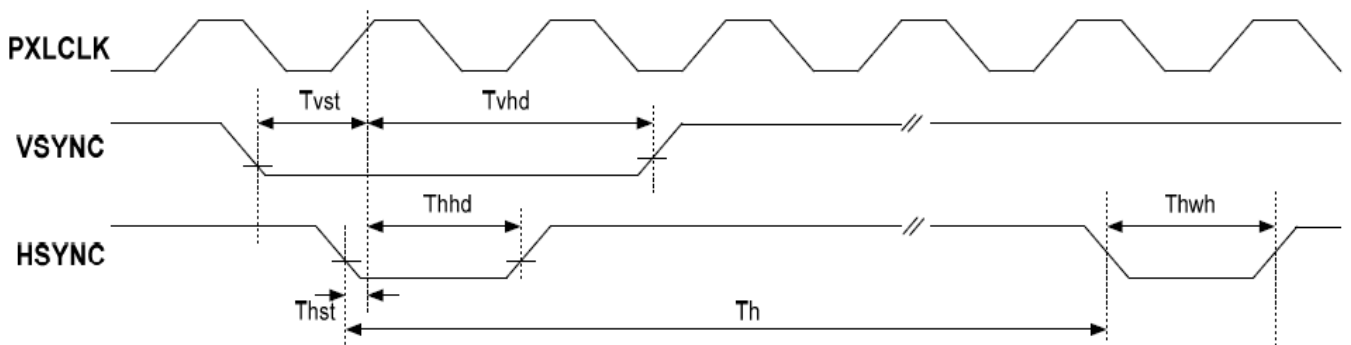
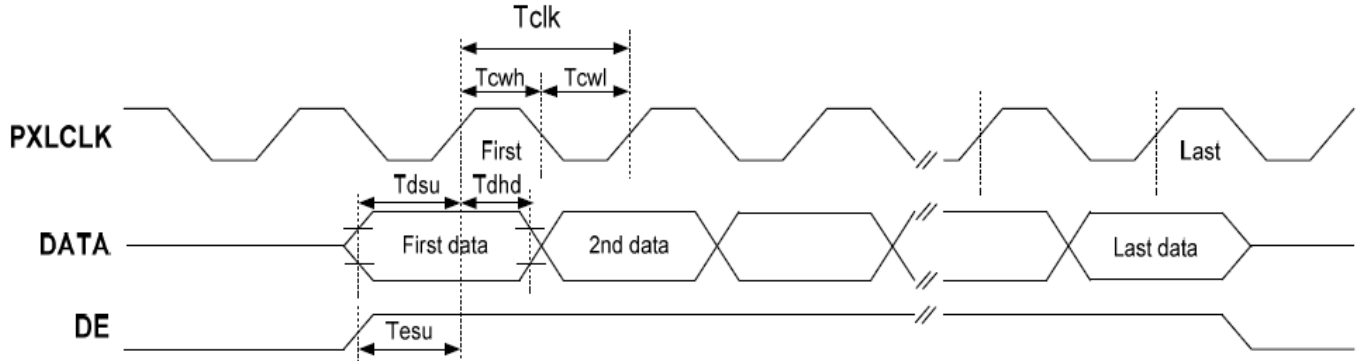

DE Mode Input Timing

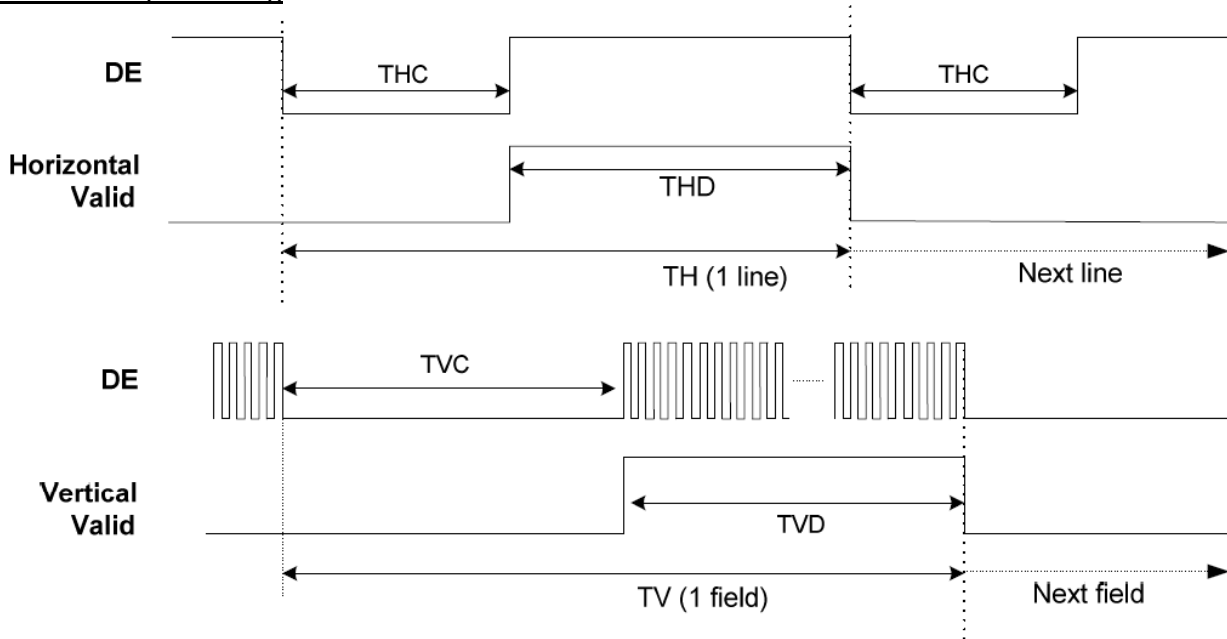

HV Mode Input Timing

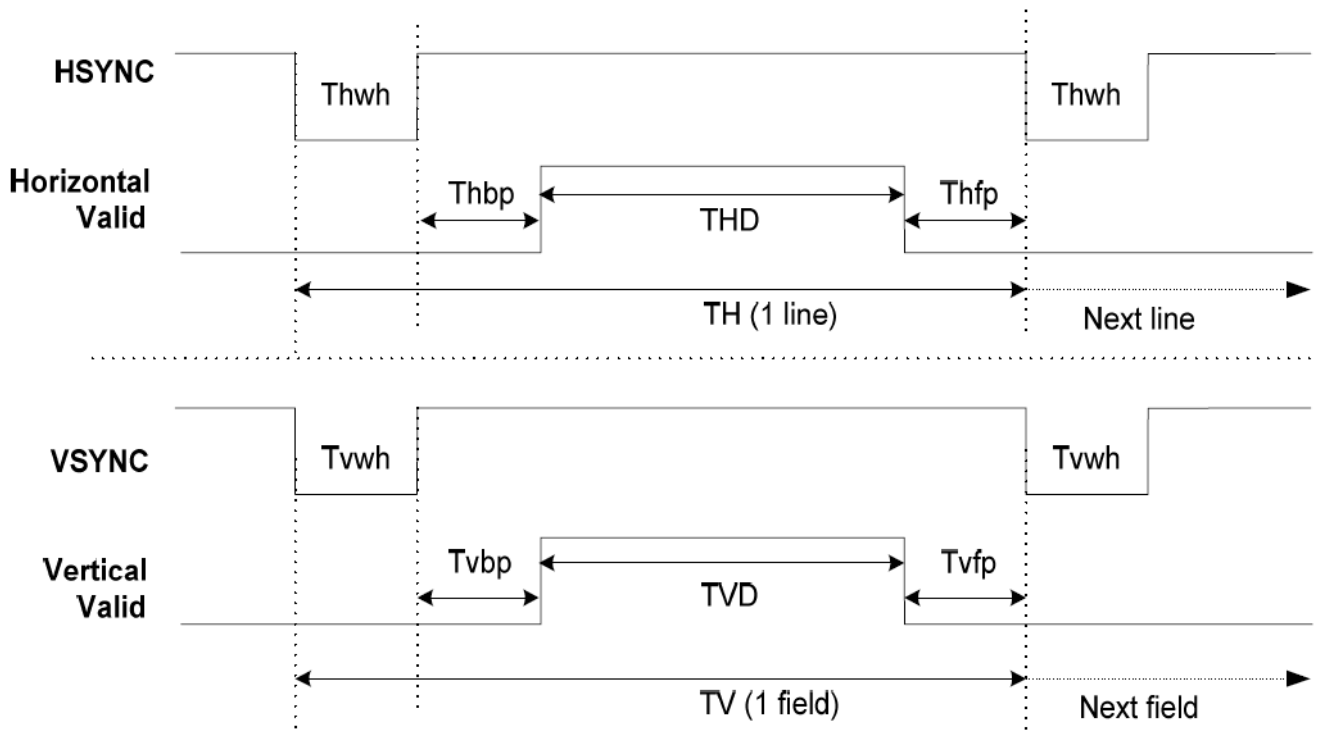

24 bit RGB mode for 640 x(RGB)x 480

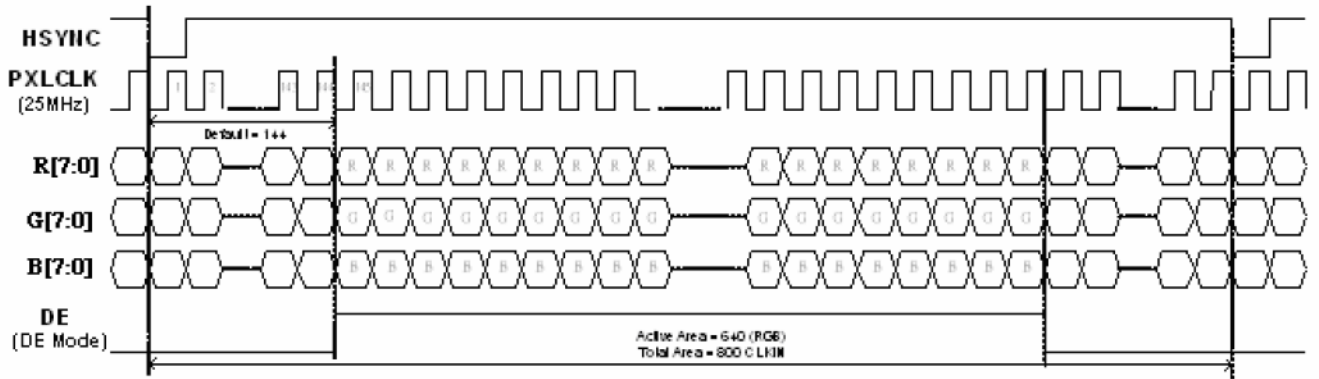
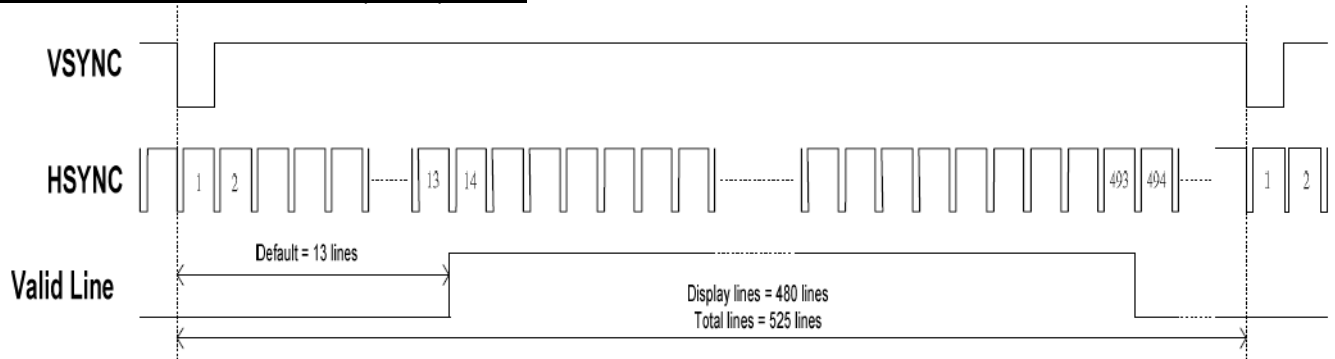

8.3 power sequence

8.3.1 power on:

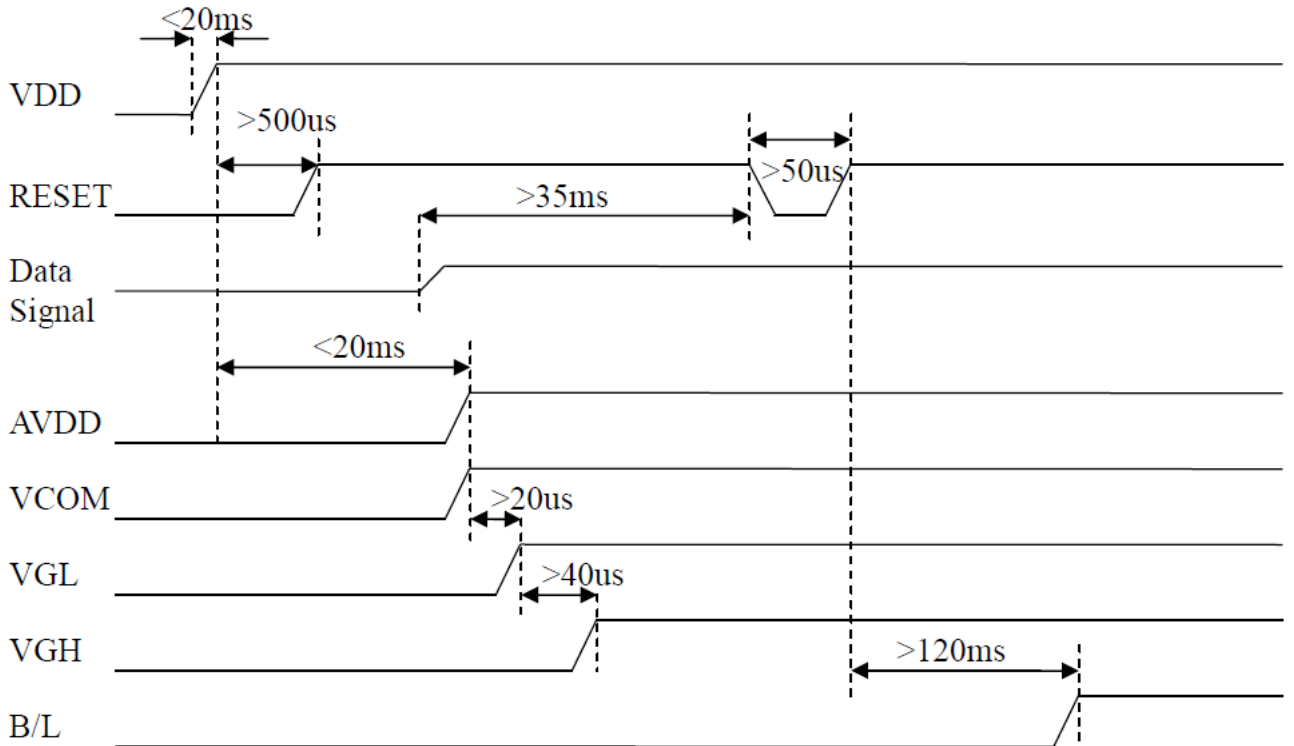

8.3.2 power off:

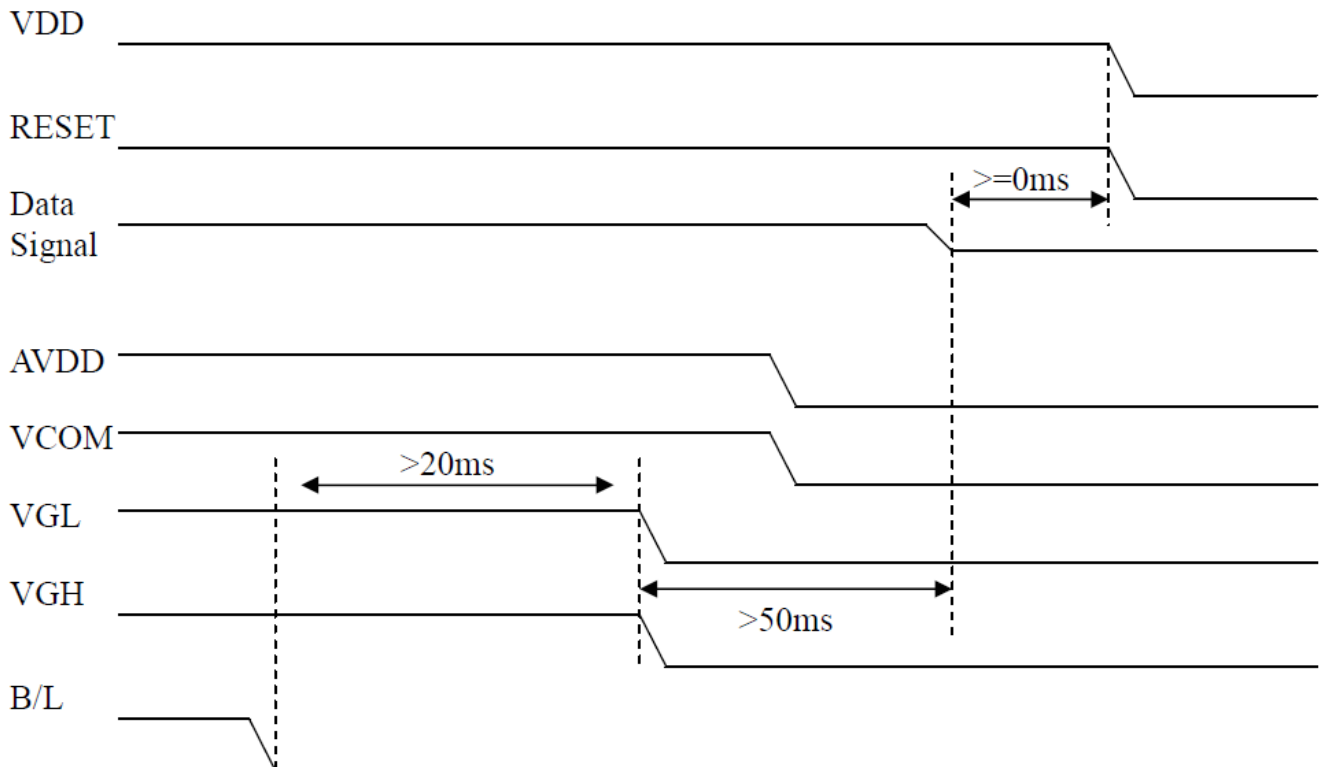

Note: Data includes DE, VS, HS, B0~B7, G0~G7, R0~R7, DCLK.

9. Optical Specification

Ta=25°C

Item	Symbol	Condition	Min	Typ.	Max.	Unit	Remark	
Contrast Ratio	CR	$\theta=0^\circ$	400	500	-		Note1 Note2	
Response Time	Tr/ Tf	25°C	-	10	20	ms	Note1 Note3	
				15	30			
View Angles	ΘT	$CR \geq 10$	40	50	-	Degree	Note 4	
	ΘB			60	70			-
	ΘL			60	70			-
	ΘR			60	70			-
Chromaticity	White	Brightness is on	Typ-0.05	0.31	Typ+0.05		Note5, Note1	
				0.33				
Luminance	L		200	250	-	cd/m ²	Note1 Note6	
Uniformity	U		70	75	-	%	Note1 Note7	

Note 1: Definition of optical measurement system.

Temperature = 25°C (±3°C)

LED back-light: ON, Environment brightness < 150 lx

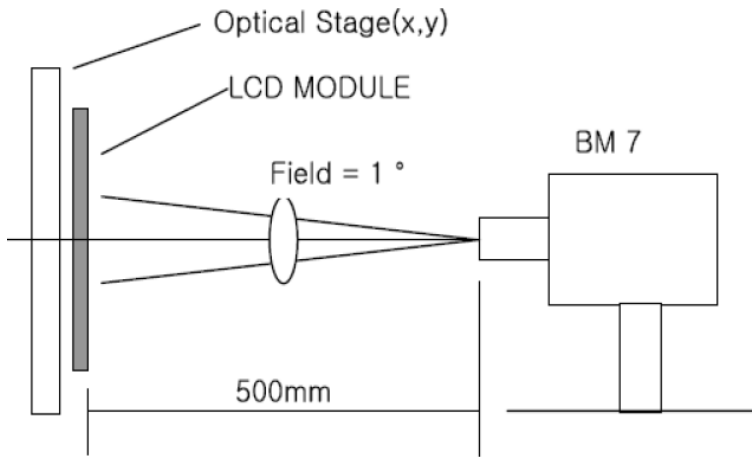

Note 2: Contrast ratio is defined as follow:

$$\text{Contrast Ratio} = \frac{\text{Surface Luminance with all white pixels}}{\text{Surface Luminance with all black pixels}}$$

Note 3: Response time is defined as follow:

Response time is the time required for the display to transition from black to white (Rise Time, Tr) and from white to black (Decay Time, Tf).

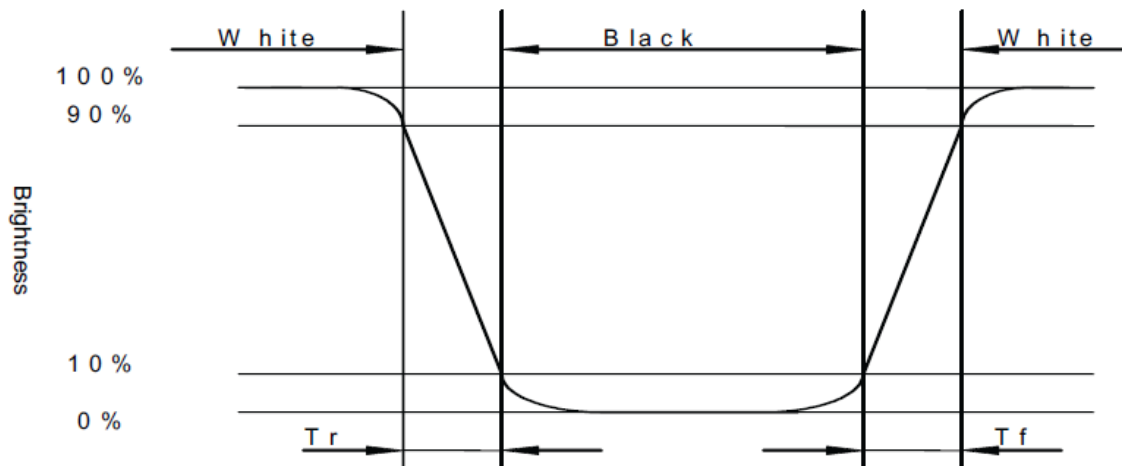

Note 4: Viewing angle range is defined as follow:

Viewing angle is measured at the center point of the LCD.

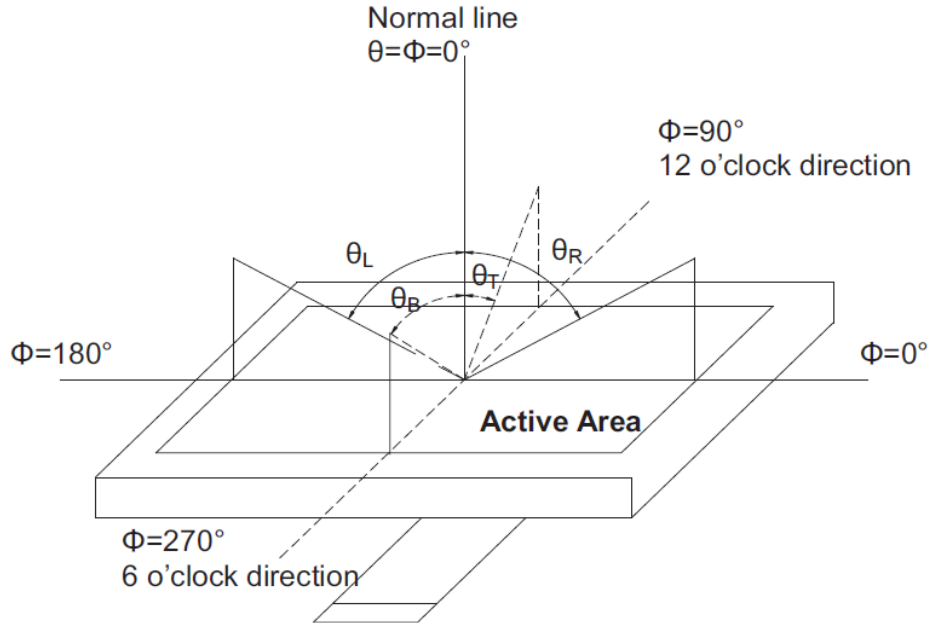

Note 5: Color chromaticity is defined as follow: (CIE1931)

Color coordinates measured at center point of LCD.

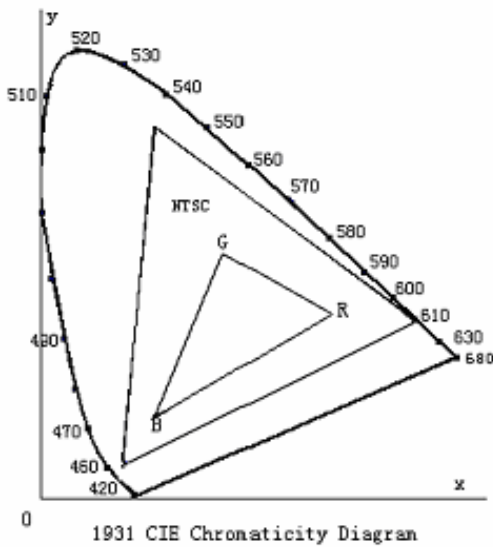

$$S = \frac{\text{area of RGB triangle}}{\text{area of NTSC triangle}} \times 100\%$$

Note 6: Luminance is defined as follow:

Luminance is defined as the brightness of all pixels “White” at the center of display area on optimum contrast.

Note 7: Luminance Uniformity is defined as follow:

Active area is divided into 9 measuring areas (Refer Fig. 2). Every measuring point is placed at the center of each measuring area.

$$\text{Uniformity (U)} = \frac{\text{Minimum Luminance(brightness) in 9 points}}{\text{Maximum Luminance(brightness) in 9 points}}$$

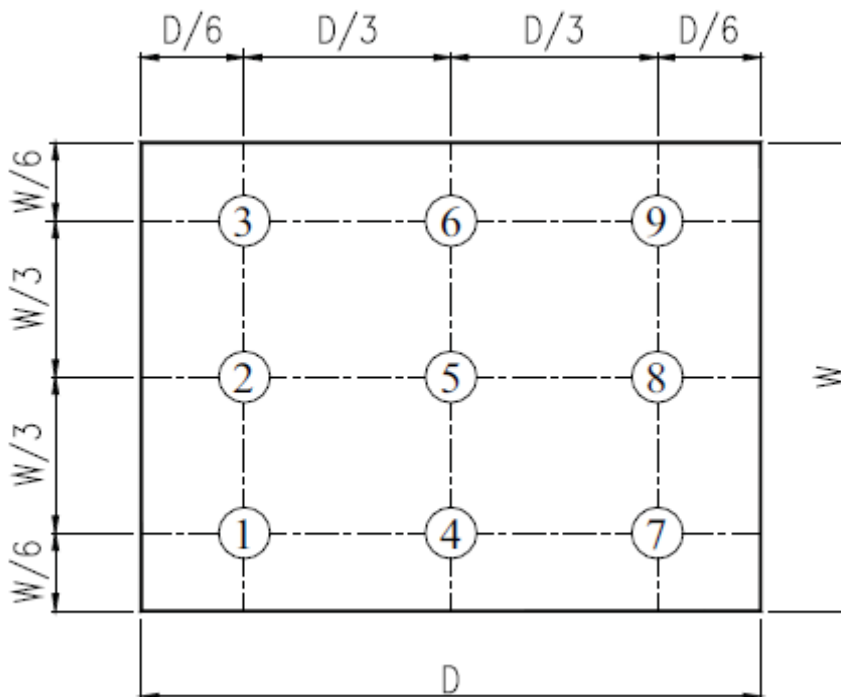

Fig. 2 Definition of uniformity

10. Environmental / Reliability Tests

No	Test Item	Condition	Judgment criteria
1	High Temp Operation	Ts=+70°C, 120hrs	Per table in below
2	Low Temp Operation	Ta=-20°C, 120hrs	Per table in below
3	High Temp Storage	Ta=+80°C, 120hrs	Per table in below
4	Low Temp Storage	Ta=-30°C, 120hrs	Per table in below
5	High Temp & High Humidity Storage	Ta=+40°C, 90% RH 120 hours	Per table in below (polarizer discoloration is excluded)
6	Thermal Shock (Non-operation)	-30°C 30 min~+80°C 30 min, Change time:5min, 10 Cycles	Per table in below
7	ESD (Operation)	C=150pF, R=330Ω · 5points/panel Air:±8KV, 5times; Contact:±4KV, 5 times;	Per table in below
8	Vibration (Non-operation)	Frequency range:10~55Hz, Stroke:1.5mm Sweep:10Hz~55Hz~10Hz 2 hours for each direction of X.Y.Z.	Per table in below
9	Shock (Non-operation)	60G 6ms, ±X,±Y,±Z 3times, for each direction	Per table in below
10	Package Drop Test	Height:80 cm, 1 corner, 3 edges, 6 surfaces	Per table in below

INSPECTION	CRITERION(after test)
Appearance	No Crack on the FPC, on the LCD Panel
Alignment of LCD Panel	No Bubbles in the LCD Panel No other Defects of Alignment in Active area
Electrical current	Within device specifications
Function / Display	No Broken Circuit, No Short Circuit or No Black line No Other Defects of Display

11. Precautions for Use of LCD Modules

11.1 Safety

The liquid crystal in the LCD is poisonous. Do not put it in your mouth. If the liquid crystal touches your skin or clothes, wash it off immediately using soap and water.

11.2 Handling

- A. The LCD and touch panel is made of plate glass. Do not subject the panel to mechanical shock or to excessive force on its surface.
- B. Do not handle the product by holding the flexible pattern portion in order to assure the reliability
- C. Transparency is an important factor for the touch panel. Please wear clear finger sacks, gloves and mask to protect the touch panel from finger print or stain and also hold the portion outside the view area when handling the touch panel.
- D. Provide a space so that the panel does not come into contact with other components.
- E. To protect the product from external force, put a covering lens (acrylic board or similar board) and keep an appropriate gap between them.
- F. Transparent electrodes may be disconnected if the panel is used under environmental conditions where dew condensation occurs.
- G. Property of semiconductor devices may be affected when they are exposed to light, possibly resulting in IC malfunctions.
- H. To prevent such IC malfunctions, your design and mounting layout shall be done in the way that the IC is not exposed to light in actual use.

11.3 Static Electricity

- A. Ground soldering iron tips, tools and testers when they are in operation.
- B. Ground your body when handling the products.
- C. Power on the LCD module before applying the voltage to the input terminals.
- D. Do not apply voltage which exceeds the absolute maximum rating.
- E. Store the products in an anti-electrostatic bag or container.

11.4 Storage

- A. Store the products in a dark place at $+25^{\circ}\text{C} \pm 10^{\circ}\text{C}$ with low humidity (40% RH to 60% RH). Don't expose to sunlight or fluorescent light.
- B. Storage in a clean environment, free from dust, active gas, and solvent.

11.5 Cleaning

- A. Do not wipe the touch panel with dry cloth, as it may cause scratch.
- B. Wipe off the stain on the product by using soft cloth moistened with ethanol. Do not allow ethanol to get in between the upper film and the bottom glass. It may cause peeling issue or defective operation. Do not use any organic solvent or detergent other than ethanol.

11.6 Cautions for installing and assembling

Bezel edge must be positioned in the area between the Active area and View area. The bezel may press the touch screen and cause activation if the edge touches the active area. A gap of approximately 0.5mm is needed between the bezel and the top electrode. It may cause unexpected activation if the gap is too narrow. There is a tolerance of 0.2 to 0.3mm for the outside dimensions of the touch panel and tail. A gap must be made to absorb the tolerance in the case and connector.

