



ALL SHORE INDUSTRIES, INC.

SPECIFICATION FOR LIQUID CRYSTAL DISPLAY MODULE

MODULE # : ASI-B-24012BS-HE-_WD/X

Dot matrix	240 x 128 dots
Controller IC	T6963C or equivalent
Dimensional Outline	144 x 104 x 10.3mm
Viewing Area	114 x 64mm
Active Viewing Area	107.98 x 57.58mm
Dot Pitch	0.43 x 0.43mm
Dot Size	0.45 x 0.45
Viewing Direction	6 o'clock
LCD mode	FSTN, Transflective
Backlight mode	White EL Backlight



MODEL NO : ASI-B-24012BS-HE-_WD/X

LCD MODULE PART NUMBERING SYSTEM

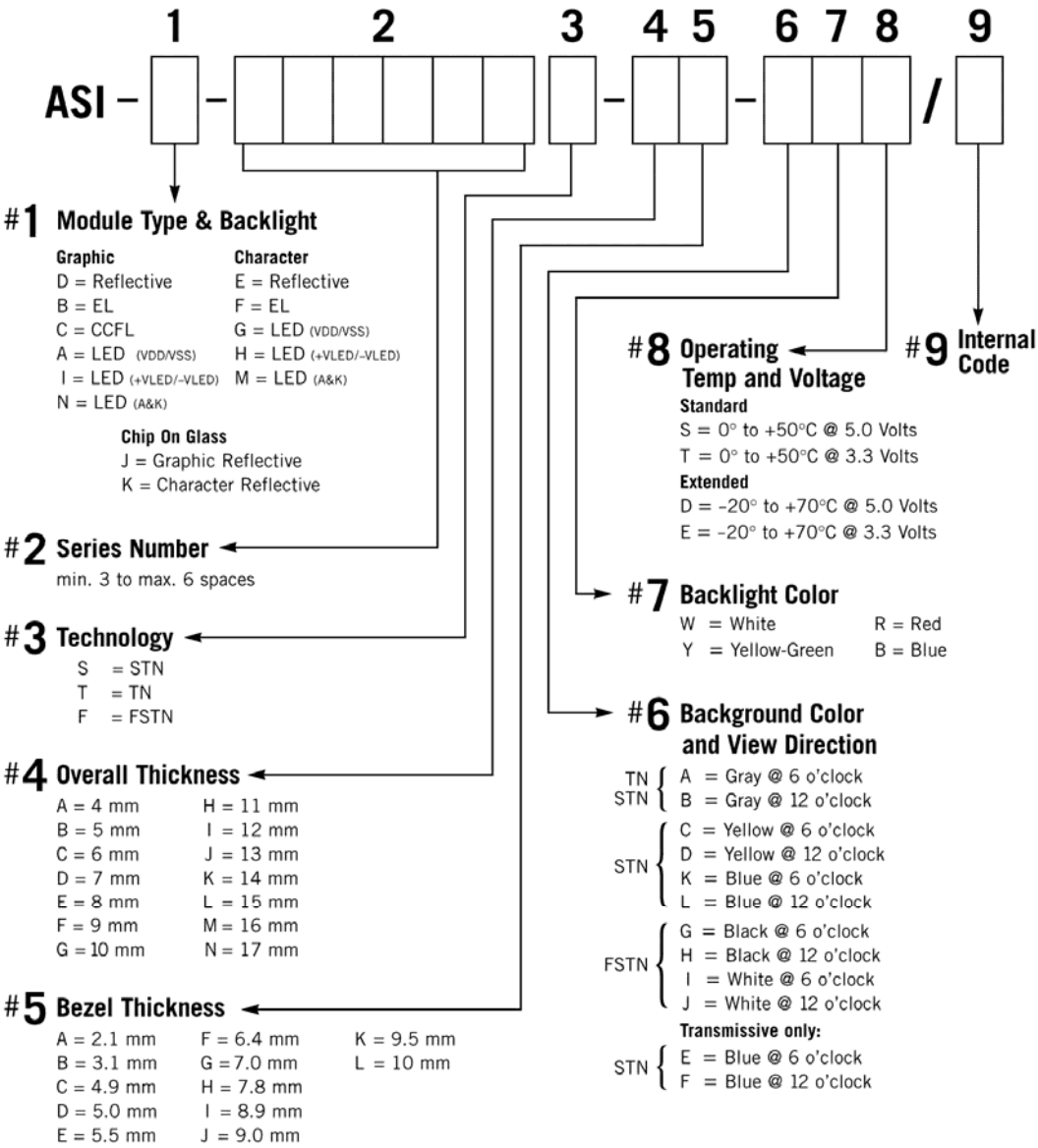

NOTE: Some options may not be available in specific modules. Please contact your Sales Representative to check availability.



MODEL NO : ASI-B-24012BS-HE-_WD/X

TABLE OF CONTENTS

NO.	ITEM	PAGE
1.	GENERAL AND MECHANICAL CHARACTERISTICS	4
2.	ABSOLUTE MAXIMUM RATINGS	4
3.	ELECTRICAL CHARACTERISTICS	4
4.	ELECTRO-OPTICAL CHARACTERISTICS	4 – 5
5.	POWER SUPPLY FOR LCD MODULE AND CONTRAST ADJUST	6
6.	BACKLIGHT INFORMATION	6
7.	PIN CONNECTION	7
8.	DIMENSIONAL DRAWING	8
9.	BLOCK DIAGRAM	9
10.	DISPLAY CONTROL INSTRUCTIONS	10 – 31
11.	TIMING CHARACTERISTICS	32
12.	QUALITY ASSURANCE	33
13.	RELIABILITY	33



MODEL NO : ASI-B-24012BS-HE-_WD/X

1. GENERAL AND MECHANICAL CHARACTERISTICS

Dot matrix	240 x 128 dots
Controller IC	T6963C or equivalent
Dimensional Outline	144 x 104 x 10.3mm
Viewing Area	114 x 64mm
Active Viewing Area	107.98 x 57.58mm
Dot Pitch	0.43 x 0.43mm
Dot Size	0.45 x 0.45
Viewing Direction	6 o'clock
LCD mode	FSTN, Transflective
Backlight mode	White EL Backlight

2. ABSOLUTE MAXIMUM RATINGS:

2.1. Electrical absolute maximum rating

ITEM	SYMBOL	MIN	TYP.	MAX	UNIT
Supply Voltage for Logic	$V_{DD} - V_{SS}$	4.75	--	5.25	V
LCD Driver Circuit Supply Voltage	$V_{DD} - V_0$	Ta = -20° C Ta = 25° C Ta = 70° C	--	21.0	V
Input Voltage	V_I	V_{SS}	--	V_{DD}	V
Operating Temperature	V_{OP}	-20	--	+70	°
Storage Temperature	V_{ST}	-30	--	+80	°
EL forward current	IEL	--	--	9.7	mA

3. ELECTRICAL CHARACTERISTICS

ITEM	SYMBOL	CONDITION	MIN.	TYP	MAX	UNIT
Logic Circuit Power Supply	$V_{DD} - V_{SS}$	--	4.75	--	5.25	V
LCD Driver Power Supply	$V_{DD} - V_0$	Ta = -20° C Ta = 25° C Ta = 70° C	--	19.5 18.0 16.5	--	V
Input Voltage	V_{IH}	--	2.2	--	V_{DD}	V
	V_{IL}		0	--	0.8	V
Output Voltage	V_{OH}	--	2.4	--	V_{DD}	V
	V_{OL}		0	--	0.4	V
Power Supply Current	I_{DD}	$V_{DD}=5V$	--	16	--	mA

4. ELECTRO-OPTICAL CHARACTERISTICS

ITEM	SYMBOL	CONDITION	MIN.	TYP	MAX	UNIT
Viewing Angle	(V) θ	$Cr \geq 2$	10		40	Deg
	(H) ϕ	$Cr \geq 2$	-30		30	Deg
Contrast	Cr	--		5		--
Response Time	Rise Time	--		200	300	ms
	Fall Time	--		150	250	ms

MODEL NO : ASI-B-24012BS-HE-_WD/X

4.1. DEFINITIONS

■ **View Angles**

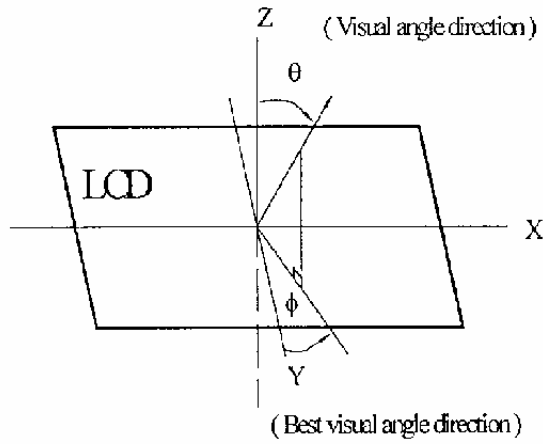

■ **Contrast Ratio**

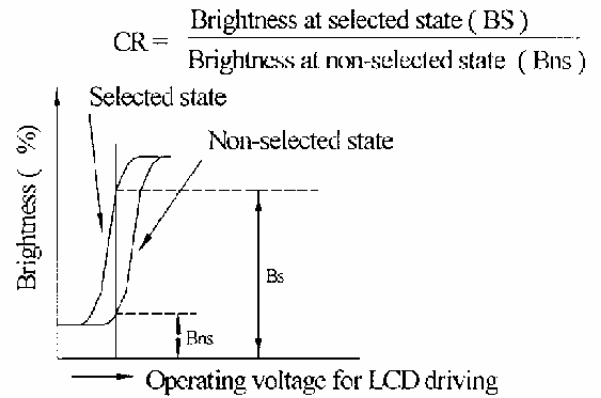

■ **Response Time**

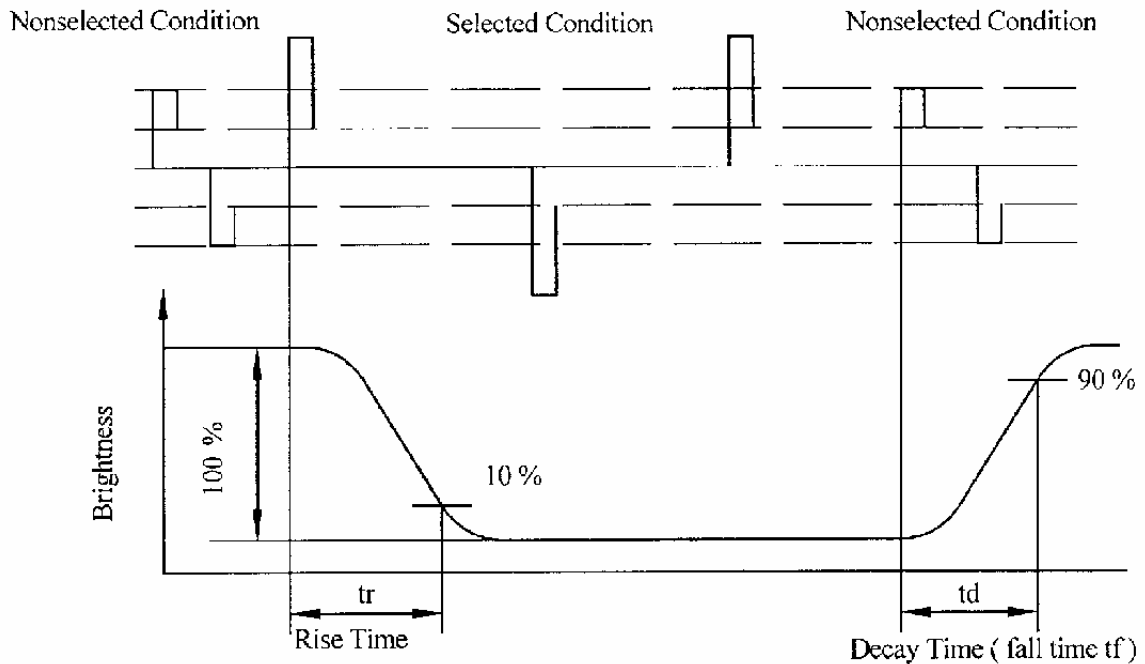



MODEL NO : ASI-B-24012BS-HE-_WD/X

5. POWER SUPPLY FOR LCD MODULE AND CONTRAST ADJUST

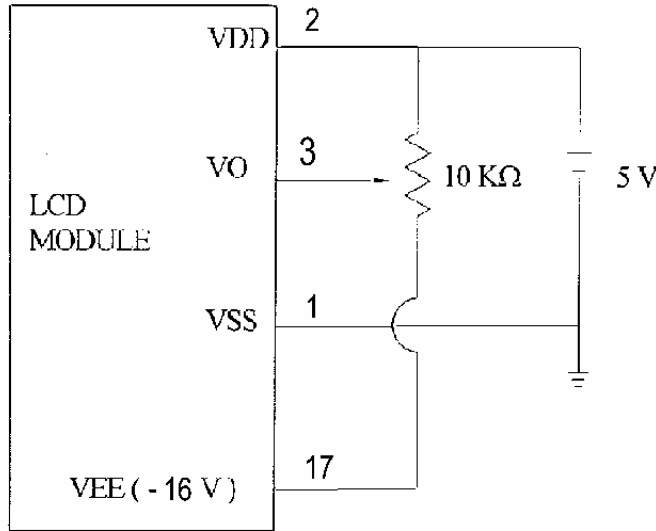

VDD-V0:LCD Operating Voltage

6. BACKLIGHT INFORMATION

Parameter	Symbol	Min	Typ	Max	Unit	Test Condition
Driving Voltage	V _{max}	--	110	170	V _{rms}	25° C
Drive Wave	F _{max}	--	400	1000	Hz	25° C
Brightness		48	60	--	cd/m ²	100V/400Hz
Power consumption		150	200	--	mW	100V/400Hz
Chromatism	X	--	0.3173	--	--	100V/400Hz
	Y	--	0.3995	--	--	100V/400Hz
Life Time			50000		Hr.	100V/400Hz
Color	Yellow Green		White		--	Light on 110V/400Hz

MODEL NO : ASI-B-24012BS-HE-_WD/X

7. DIMENSIONAL DRAWING

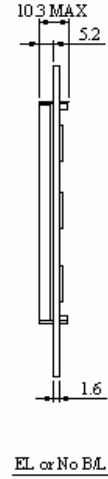
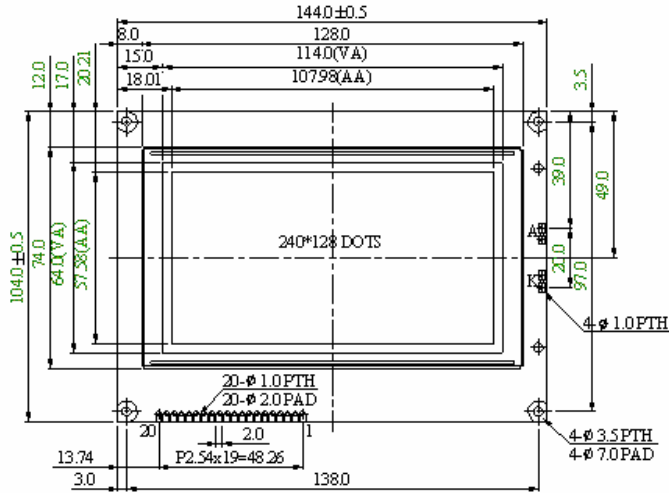

PIN NO.	SYMBOL
1	V _{ss}
2	V _{dd}
3	V _o
4	C/D
5	RD
6	WR
7	DB0
8	DB1
9	DB2
10	DB3
11	DB4
12	DB5
13	DB6
14	DB7
15	CE
16	RESET
17	V _{ee}
18	MD2
19	FS1
20	NC

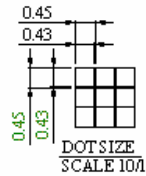



MODEL NO : ASI-B-24012BS-HE-_WD/X

8. PIN CONNECTIONS

NO.	SYMBOL	LEVEL	DESCRIPTION
1	V _{SS}		GROUND
2	V _{DD}		POWER (+5V)
3	V ₀		Power Supply FOR LCD DRIVER
4	C/D	H/L	WR=L, C/D=H; COMMAND WRITE C/D=L:DATA WRITE RD=L, C/D=H, STATUS READ C/D=L:DATA READ
5	RD	L	Data read. Read data from T6963C when RD = L
6	WR	L	Data write. Write data from T6963C when WR = L
7	DB0	H/L	Data bus line
8	DB1	H/L	Data bus line
9	DB2	H/L	Data bus line
10	DB3	H/L	Data bus line
11	DB4	H/L	Data bus line
12	DB5	H/L	Data bus line
13	DB6	H/L	Data bus line
14	DB7	H/L	Data bus line
15	CE	L	L: CHIP ENABLE
16	RESET	H/L	H: NORMAL; L: INITIALIZE T6963C
17	V _{ee}		NEGATIVE VOLTAGE OUTPUT (-16V)
18	MD2	H/L	H: 32 COLUMNS; L: 40 COLUMNS
19	FS	H/L	Pins for selection of font ; H: 6 * 8, L : 8 * 8
20	N.C.		No connection



MODEL NO : ASI-B-24012BS-HE-_WD/X

10. DISPLAY CONTROL INSTRUCTION

The LCD module has built in a T6963C. LSI controller, It has an 8-bit parallel data bus and control lines for writing or reading through an MPU interface, it has a 128-word character generator ROM (refer to table 1.), which can control an external display RAM of up to 8K bytes. Allocation of text, graphics and external character generator RAM can be made easily and the display window can be moved freely within the allocated memory range.

- **RAM Interface**

The external RAM is used to store display data (text, graphics and external CG data). It can be freely allocated to the memory area (8K byte max).

Recommend

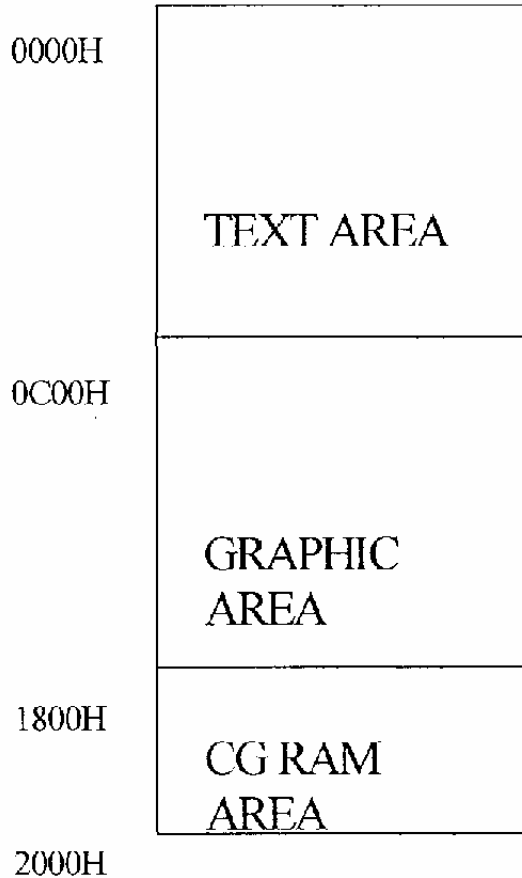



MODEL NO : ASI-B-24012BS-HE-_WD/X

- **Flowchart of communications with MPU**

(1) Status Read

A status check must be performed before data is read or written.

Status check

The Status of T6963C can be read from the data lines.

$\overline{\text{RD}}$	L
$\overline{\text{WR}}$	H
$\overline{\text{CE}}$	L
C/D	H
D0 to D7	H

The T6963C status word format is as follows:

MSB							LSB
STA7	STA6	STA5	STA4	STA3	STA2	STA1	STA0
D7	D6	D5	D4	D3	D2	D1	D0

STA0	Check command execution capability	0:Disable 1:Enable
STA1	Check data read/write Capability	0:Disable 1:Enable
STA2	Check Auto mode data read capability	0:Disable 1:Enable
STA3	Check Auto mode data write capability	0:Disable 1:Enable
STA4	Not used	
STA5	Check controller operation capability	0:Disable 1:Enable
STA6	Error flag. Used for Screen Peek and Screen copy commands.	0:No Error 1:Error
STA7	Check the blink condition.	0:Disable off 1:Normal display

(Note 1) It is necessary to check STA0 and STA1 at the same time.

There is a possibility of erroneous operation due to a hardware interrupt.

(Note 2) For most modes STA0/STA1 are used as status check.

(Note 3) STA2 and STA3 are valid in Auto mode; STA0 and STA1 are invalid.

Status Checking flow

MODEL NO : ASI-B-24012BS-HE-_WD/X

(a)

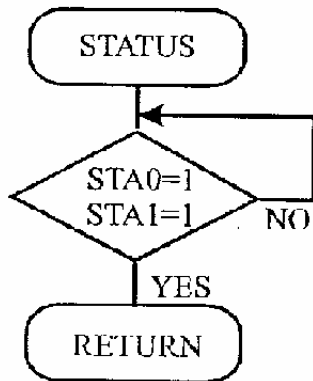

(b)

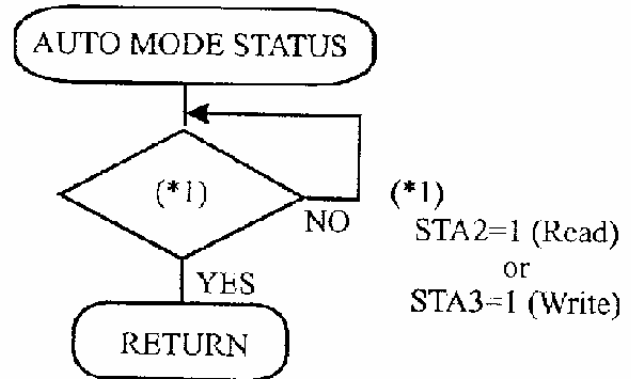

- (Note 4) When using the MSB=0 command, a Status Read must be performed.
 If a status check is not carried out, the T6963C cannot operate normally, even after a delay time.
 The hardware interrupt occurs during the address calculation period (at the end of each line)
 If a MSB=0 command is sent to the T6963C during this period, the T6963C enters Wait status.
 If a status check is not carried out in this state before the next command is sent, there is the possibility that the command or data date will not be received.



MODEL NO : ASI-B-24012BS-HE-_WD/X

(2) Setting date

When using the T6963C, first set the data, then set the command.

Procedure for sending a command

(a)The case of 1 date

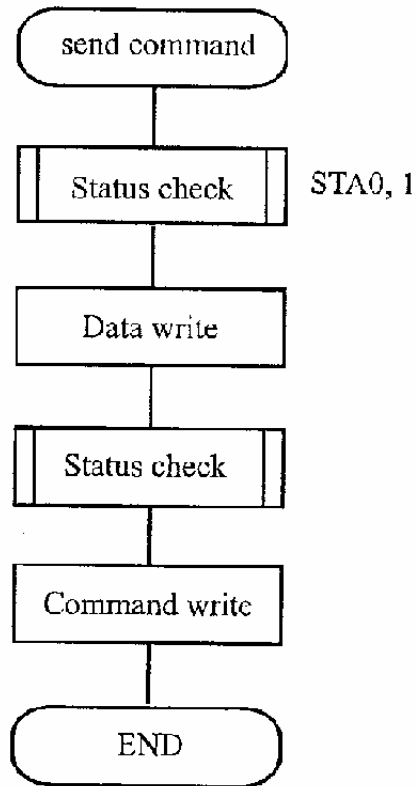

(b)The case of 2 data

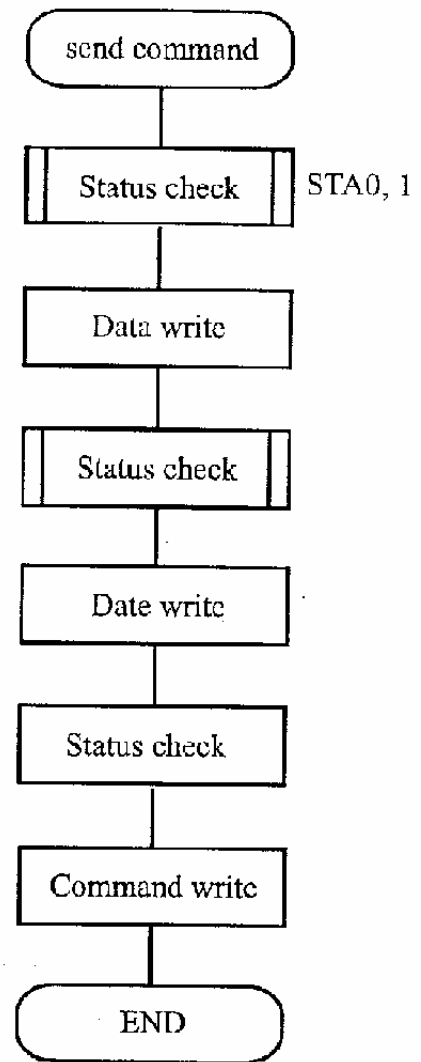

(Note) When sending more than two data, the last datum (or last two data) is data.



MODEL NO : ASI-B-24012BS-HE-_WD/X

COMMAND DEFINITIONS

COMMAND	CODE	D1	D2	FUNCTION
REGISTERS SETTING	00100001	X address	Y address	Set Cursor Pointer
	00100010	Date	00H	Set Offset Register
	00100100	Low address	High address	Set Address Pointer
SET CONTROL WORD	01000000	Low address	High address	Set Text Home Address
	01000001	Columns	00H	Set Text Area
	01000010	Low address	High address	Set Graphic Home Address
	01000011	Columns	00H	Set Graphic Area
MODE SET	1000x 000	-	-	Or mode
	1000x 001	-	-	EXOR mode
	1000x 011	-	-	AND mode
	1000x 100	-	-	Text Attribute mode
	10000x x x	-	-	Internal CG ROM mode
	10001x x x	-	-	External CG RAM mode
DISPLAY MODE	10010000	-	-	Display off
	1001x x10	-	-	Cursor on, blink off
	10001x x 11	-	-	Cursor on, blink on
	100101x x	-	-	Text on, graphic off
	100110x x	-	-	Text off, graphic on
	100111x x	-	-	Text on, graphic on
CURSOR PATTERN SELECT	10100000	-	-	1-line cursor
	10100001	-	-	2-line cursor
	10100010	-	-	3-line cursor
	10100011	-	-	4-line cursor
	10100100	-	-	5-line cursor
	10100101	-	-	6-line cursor
	10100100	-	-	7-line cursor
	10100111	-	-	8-line cursor
DATA AUTO READ/WRITE	10110000	-	-	Set Data Auto Write
	10110001	-	-	Set Data Auto Read
	10110010	-	-	Auto Reset
DATA READ/WRITE	11000000	Data	-	Data Write and Increment ADP
	11000001	-	-	Data Read and Increment ADP
	11000010	Data	-	Data Write and Decrement ADP
	11000011	-	-	Data Read and Decrement ADP
	11000100	Data	-	Data Write and Nonvariable ADP
	11000101	-	-	Data Read and Nonvariable ADP
SCREEN PEEK	11100000	-	-	Screen Peek

COMMAND	CODE	D1	D2	FUNCTION
SCREEN COPY	11101000			Screen Copy
BIT SET/RESET	11110x x x	-	-	Bit Reset
	11111x x x	-	-	Bit Set
	1111x 000	-	-	Bit 0 (LSB)
	11111x 001	-	-	Bit 1
	11111x 010	-	-	Bit 2
	11111x 011	-	-	Bit 3
	11111x 100	-	-	Bit 4
	11111x 101	-	-	Bit 5
	11111x 110	-	-	Bit 6
	11111X 111	-	-	Bit 7 (MSB)

All Shore Industries, Inc. One Edgewater Plaza, Staten Island, NY 10305



MODEL NO : ASI-B-24012BS-HE-_WD/X

- Setting Registers

CODE	HEX.	FUNCTION	D1	D2
00100001	21H	SET CURSOR POINTER	X ADRS	Y ADRS
00100010	22H	SET OFFSET REGISTER	DATA	00H
00100100	24H	SET ADDRESS POINTER	LOW ADRS	HIGH ADRS

(1) Set Cursor Pointer

The position of the cursor is specified by X ADRS and Y ADRS. The cursor position can only be moved by this command. Data read/write from the MPU never changes the cursor pointer. X ADRS and Y ADRS are specified as follows.

X ADRS 00H to 4FH (lower 7 bits are valid)

Y ADRS 00H to 1FH (lower 5 bits are valid)

Single-Scan

X ADRS 00 to 4FH

Y ADRS 00H to 0FH

(2) Set Offset Register

The offset register is used to determine the external character generator RAM area.

The T6963C has a 16-bit address bus as follows.

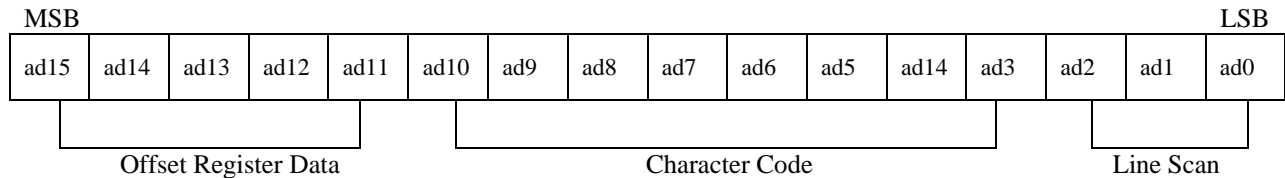

The T6963 assign External character generator, when character code set 80H to FFH is using internal character generator. Character code 00H to 80H assign External character generator, when External generator mode.

The senior five bits define the start address in external memory of the CG RAM area,. The next eight bits represent the character code of the character. In internal CG ROM, character codes 00H to 7FH represent the predefined "internal" CG ROM characters, and code 80H to FFH represent the user's own "external" characters. In external CG ROM mode, all 256 code from 00H to FFH can be used to represent the user's own characters. The three least significant bits indicate one of the eight rows of either dots that define the character's shape.



MODEL NO : ASI-B-24012BS-HE-_WD/X

The relationship between display RAM address and offset register

Offset register data	CG RAM hex. Address (start to end)
00000	0000 to 07 FFH
00001	0800 to 0FFFH
00010	1000 to 17FFH
11100	E000 to E7FFH
11101	E800 to EFFFH
11110	F000 to F7FFH
11111	F800 to FFFFH

(Example 1)

Offset register	02H
Character code	80H
Character generator RAM start address	0001 0100 0000 0000 1 4 0 0 H

	(address)	(data)
	1400H	00H
	1401H	1FH
	1402H	04H
	1403H	04H
	1404H	04H
	1405H	04H
	1406H	04H
	1407H	00H



MODEL NO : ASI-B-24012BS-HE-_WD/X

(Example 2)

	(RAM DATA)	(Character)
<div style="border: 1px solid black; padding: 5px; display: inline-block;"> AB γ DE ζ GHIJKLM </div> <p>Display character</p>	21H	A
	22H	B
	83H	γ
	24H	D
	25H	E
	86H	ζ

γ and ζ are displayed by character generator RAM.

(3) Set Address Pointer

The Set Address Pointer command is used to indicate the start address for writing to (or reading from) external RAM.

The Flowchart for Set Address Pointer command

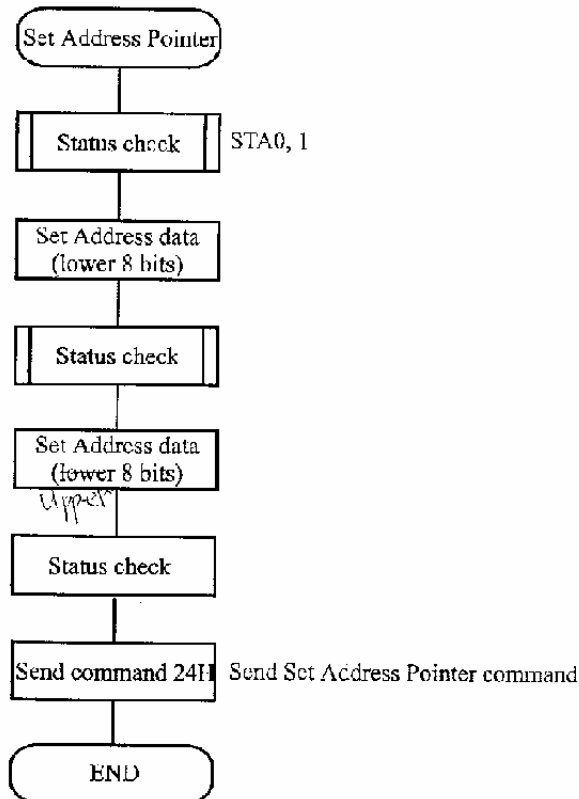



MODEL NO : ASI-B-24012BS-HE-_WD/X

Set Control Word

CODE	HEX.	FUNCTION	D1	D2
01000000	40H	SET TEXT HOME ADDRESS	Low address	High address
01000001	41H	SET TEXT AREA	Columns	00H
01000010	42H	SET GRAPHIC HOME ADDRESS	Low address	High address
01000011	43H	SET GRAPHIC AREA	Columns	00H

The home address and column size are defined by this command.

(1) Set Text Home Address

The starting address in the external display RAM for text display is defined by this command.

The text home address indicates the leftmost and uppermost position.

The relationship between external display RAM address and display position

TH		TH+CL
TH+TA		TH+TA+CL
(TH+TA)+TA		TH+2TA+CL
(TH+2TA)+TA		TH+3TA+CL
TH+(n-1)TA		TH+(n-1)TA+CL

TH: Text home address

TA: Text area number (columns)

CL: Columns are fixed by hardware (pin-programmable)

(Example)

Text Home address : 0000H
 Text area : 0020H
 : 32 columns
 : 4 lines

0000H	0001H		001EH	001FH
0020H	0021H		003EH	002FH
0040H	0041H		005EH	005FH
0060H	0061H		007EH	007FH



MODEL NO : ASI-B-24012BS-HE-_WD/X

(2) Set Graphic Home Address

The starting address in the external display RAM for graphic display is defined by this command.

The graphic home address indicates the leftmost and uppermost position.

The relationship between external display RAM address and display position

GH		GH+CL
GH+GA		GH+TA+CL
(GH+GA)+GA		GH+2TA+CL
(GH+2GA)+GA		GH+3TA+CL
GH+(n-1)GA		GH+(n-1)GA+CL

GH: Graphic home address

GA: Graphic area number (columns)

CL: Columns are fixed by hardware (pin-programmable)

(Example)

Graphic Home address : 0000H

Graphic area : 0020H

: 32 columns

: 2 lines



MODEL NO : ASI-B-24012BS-HE-_WD/X

(4) Set Graphic Area

The display columns are defined by the hardware setting. This command can be used to adjust the columns of the graphic display.

(Example)

LCD size 20 columns, 2 lines
 Graphic home address : 0000H
 Graphic area : 0014H
 Set 32 columns, 2 lines

0000	0001	0013	0014	001F
0014	0015	0027	0028	0033
0028	0029	003B	003C	0047
003C	003D	004F	0050	005B
0050	0051	0063	0064	006F
0064	0065	0077	0078	0083
0078	0079	008B	008C	0097
008C	008D	009F	00A0	00AB
00A0	00A1	00B3	00B4	00BF
00B4	00B5	00C7	00C8	00D3
00C8	00C9	00DB	00DC	00E7
00DC	00DD	00EF	00F0	00FD
00F0	00F1	0103	0104	011F
0104	0105	0127	0128	0123
0128	0129	013B	0013C	00147
013C	013D	014F	0150	015B

-----> LCD <-----

If the graphic area setting is set to match the desired number of columns on the LCD, the addressing scheme will be automatically modified so that the start address of each line equals the end address of the previous line +1.

MODEL NO : ASI-B-24012BS-HE-_WD/X

Mode set

CODE	FUNCTION	OPERAND
1000x 000	OR Mode	--
1000x 001	EXOR Mode	--
1000x 011	AND Mode	--
1000x 100	TEXT ATTRIBUTE Mode	--
10000x x x	Internal Character Generator Mode	--
10001x x x	External Character Generator Mode	--

The display mode is defined by this command. The display mode does not change until the next command is sent. The logical OR, EXOR, AND of text or graphic display can be displayed. In internal Character Generator mode, character codes 00H to 7FH are assigned to the built-in character generator ROM. The character codes 80H to FFH are automatically assigned to the external character generator RAM.

Example

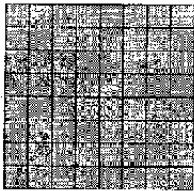

GRAPHIC

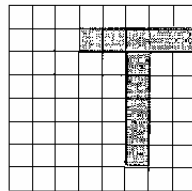

TEXT

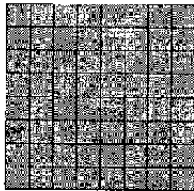

"OR"

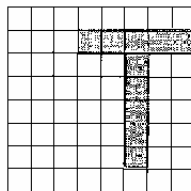

"AND"

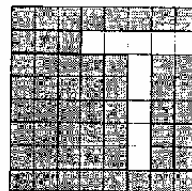

"TXOR"

(Note) Attribute functions can only be applied to text display, since the attribute data is place in the graphic RAM area.

Attribute Function

The attribute operations are Reverse display, Character blink and Inhibit. The attribute data is written into the graphic area, which was defined by the Set Control Word command. Only text display is possible in Attribute Function Mode; graphic display is automatically disabled. However, the Display Mode command must be used to turn both Text and Graphic on in order for the Attribute function to be available.

The attribute data for each character in the text area is written to the same address in the graphic area. The Attribute function is defined as follows.



MODEL NO : ASI-B-24012BS-HE-_WD/X

Attribute RAM 1 byte

x	x	x	d3	d2	d1	d0
---	---	---	----	----	----	----

d3	d2	d1	d0	FUNCTION
0	0	0	0	Normal display
0	1	0	1	Reverse display
0	0	1	1	Inhibit Display
1	0	0	0	Blink of normal display
1	1	0	1	Blink of reverse display
1	0	1	1	Blink of inhibit Display

X : invalid

CODE	FUNCTION	OPERAND
1001000	Display off	--
1001x x 10	Cursor on, Blink off	--
1001x x 11	Cursor on, Blink on	--
100101x x	Text on, graphic off	--
100110x x	Text off, graphic on	--
100111x x	Text on, Graphic on	--

X : invalid

1	0	0	1	D3	D2	D1	D0
---	---	---	---	----	----	----	----

Cursor blink	on:1,	off:0
Cursor display	on:1,	off:0
Text display	on:1,	off:0
Graphic display	on:1,	off:0

(Note) It is necessary to turn on "Text display" and "Graphic Display" in the following cases.

- Combination of text/graphic display
- Attribute function

- Cursor pattern select**

CODE	FUNCTION	OPERAND
10100000	1-line cursor	--
10100001	2-line cursor	--
10100010	3-line cursor	--
10100011	4-line cursor	--
10100100	5-line cursor	--
10100101	6-line cursor	--
10100110	7-line cursor	--
10100111	8-line cursor	--

When cursor display is on, this command selects the cursor pattern in the range 1 line to 8 lines.
The cursor address is defined by the Cursor Pointer Set command.



MODEL NO : ASI-B-24012BS-HE-_WD/X

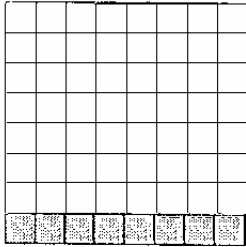

1-line cursor

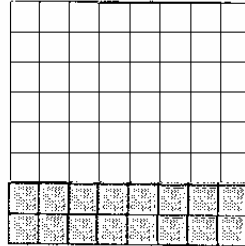

2-line cursor

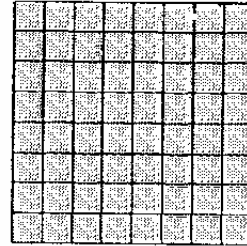

8-line cursor

Data Auto Read/Write

CODE	HEX.	FUNCTION	OPERAND
10110000	B0H	Set Data Auto Write	--
10110001	B1H	Set Data Auto Read	--
10110010	B2H	Auto Reset	--

The command is convenient for sending a full screen of data from the external display RAM. After setting Auto mode, a Data Write (or Read) command is not needed to be sent between each datum. A Data Auto Write (or Read) command must be sent after a Set Address Pointer command. After this command, the address pointer is automatically incremented by 1 after each datum. In Auto mode, the T6963C cannot accept any other commands.

The Auto Reset command must be sent to the T6963C after all data has been sent, to clear Auto mode. (Note) A Status check for Auto mode.

(STA2, STA3 should be checked between sending of each datum. Auto Reset should be performed after checking STA3=1 (STA2=1) Refer to the follow flowchart.



MODEL NO : ASI-B-24012BS-HE-_WD/X

a)Auto Read mode

b)Auto Write mode

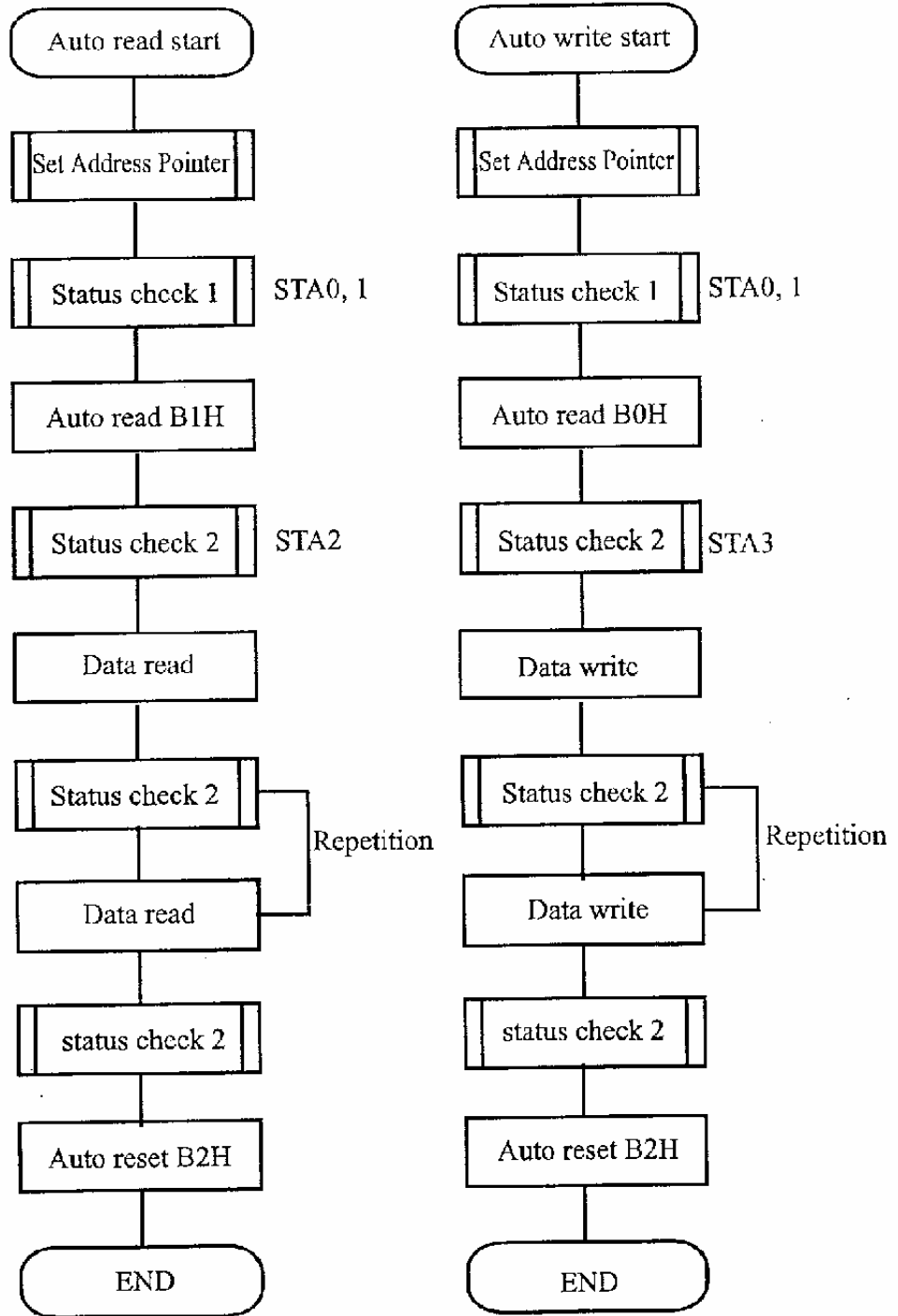



MODEL NO : ASI-B-24012BS-HE-_WD/X

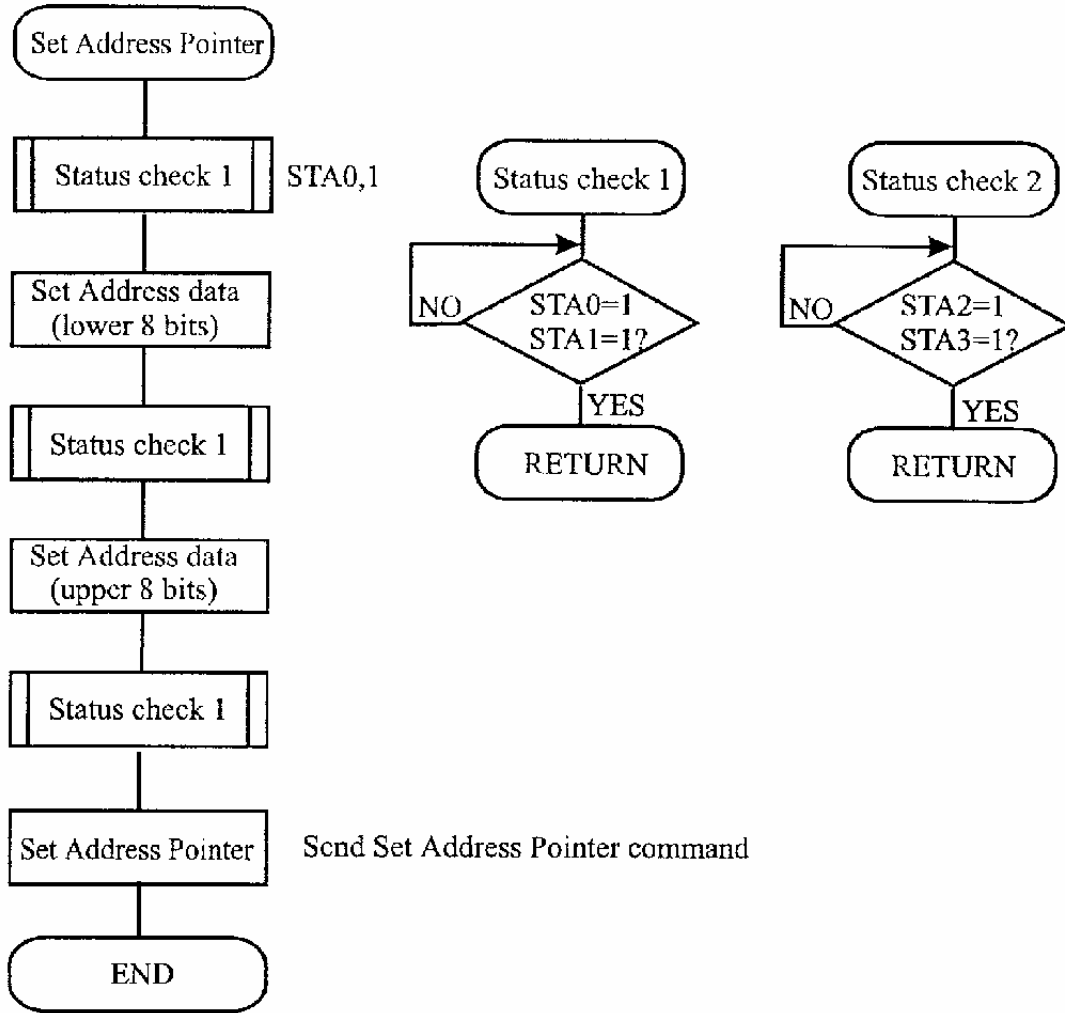



MODEL NO : ASI-B-24012BS-HE-_WD/X

- **Data Read/Write**

CODE	HEX.	FUNCTION	OPERAND
11000000	C0H	Data Write and Increment ADP	--
11000001	C1H	Data Read and Increment ADP	--
11000010	C2H	Data Write and Decrement ADP	--
11000011	C3H	Data Read and Decrement ADP	--
11000100	C4H	Data Write and Nonvariable ADP	--
11000101	C5H	Data Read and Nonvariable ADP	--

This command is used for writing data from the MPU to external display RAM, and reading data from external display RAM to the MPU. Data Write/Data Read should be executed after setting address using Set Address Pointer command. The address pointer can be automatically incremented or decremented using this command.

(Note) This command is necessary for each 1-byte datum.

Refer to the following flowchart.

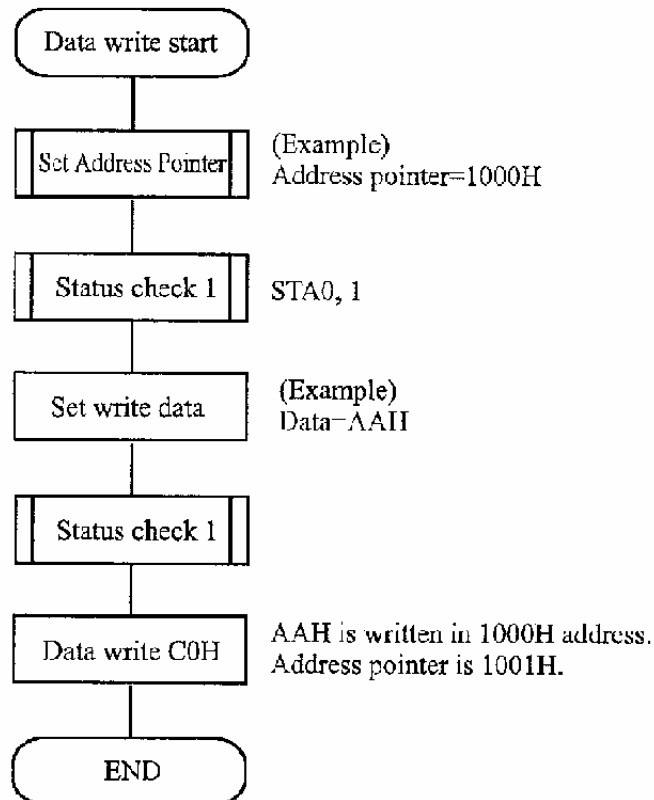



MODEL NO : ASI-B-24012BS-HE-_WD/X

- **Screen Peek**

CODE	HEX.	FUNCTION	OPERAND
11100000	E0H	Screen Peek	-e

This command is used to transfer 1 byte of displayed data to the data stack; this byte can then be read from the MPU by data access. The logical combination of text and graphic display data on the LCD screen can be read by this command.

The status (STA6) should be checked just after the Screen Peek command. If the address determined by the Set Address Pointer command is not in the graphic area, this command is ignored and a status flag (STA6) is set.

Refer to the following flowchart.

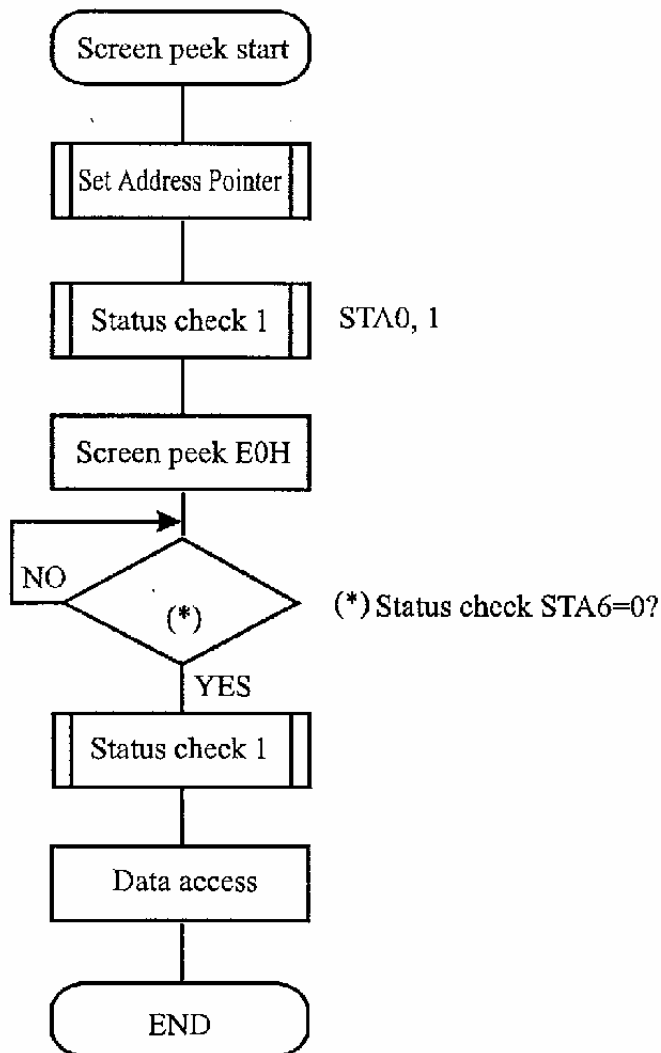



MODEL NO : ASI-B-24012BS-HE-_WD/X

- **Screen copy**

CODE	HEX.	FUNCTION	OPERAND
11101000	E8H	Screen Copy	--

This command copies a single raster line of data to the graphic area.

The start point must be set using the Set Address Pointer command.

(Note 1) If the attribute function is being used, this command is not available.
(With Attribute data is graphic area data.)

Refer to the following flowchart.

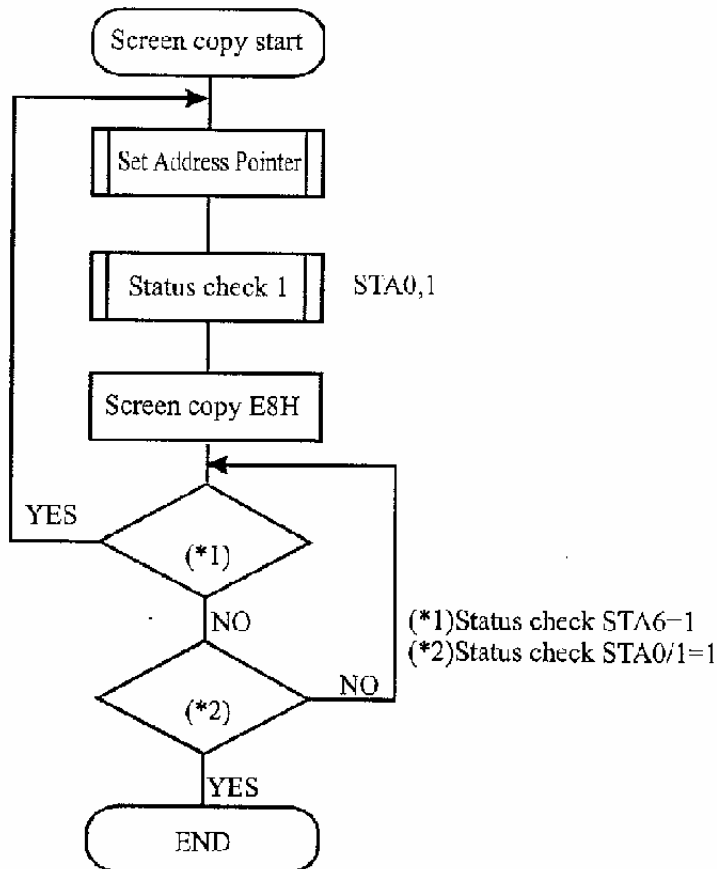



MODEL NO : ASI-B-24012BS-HE-_WD/X

- **Bit Set/Reset**

CODE	FUNCTION	OPERAND
11110x x x	Bit Reset	--
11111x x x	Bit Set	--
1111x 000	Bit 0 (LSB)	--
1111x 001	Bit 1	--
1111x 010	Bit 2	--
1111x 011	Bit 3	--
1111x 100	Bit 4	--
1111x 101	Bit 5	--
1111x 110	Bit 6	--
1111x 111	Bit 7 (MSB)	--

X:invalid

This command use to set or reset a bit of the byte specified by the address pointer.

Only one bit can be set or reset at a time.

Refer to the following flowchart.

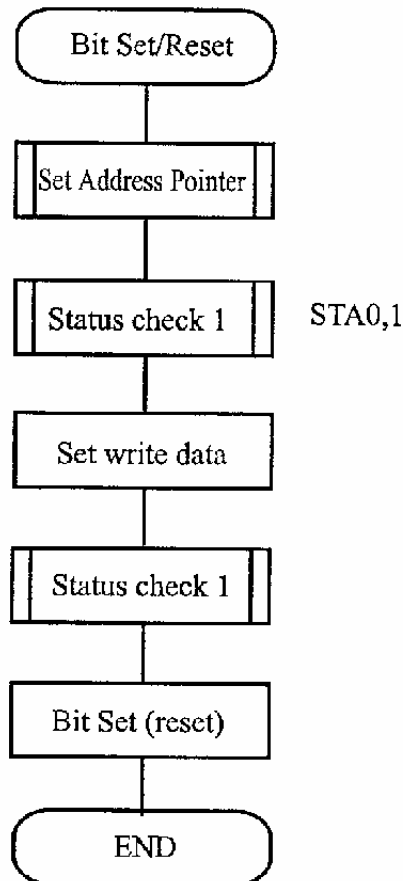



MODEL NO : ASI-B-24012BS-HE-_WD/X

• **Character Code Map**

Upper 4 bit Lower 4 bit	LLLL	LLLH	LLRL	LLRH	LLLL	LLRH	LLHL	LLHH
LLLL		0	1	2	3	4	5	6
LLLH	7	8	9	A	B	C	D	E
LLRL	F	G	H	I	J	K	L	M
LLRH	N	O	P	Q	R	S	T	U
LLLL	V	W	X	Y	Z	[\]
LLRH	^	_	`	a	b	c	d	e
LLHL	f	g	h	i	j	k	l	m
LLHH	n	o	p	q	r	s	t	u
HLLL	v	w	x	y	z	{		}
HLLH	~	0	1	2	3	4	5	6
HHLH	7	8	9	A	B	C	D	E
HHLL	F	G	H	I	J	K	L	M
HHLH	N	O	P	Q	R	S	T	U
HHLL	V	W	X	Y	Z	[\]
HHLH	^	_	`	a	b	c	d	e
HHHL	f	g	h	i	j	k	l	m
HHHH	n	o	p	q	r	s	t	u

MODEL NO : ASI-B-24012BS-HE-_WD/X

11. TIMING CHARACTERISTICS

Bus Timing
(V_{SS} = 0 V, V_{DD} = 5 V)

Item	Symbol	Min	Typ	Max	Unit
C/D Set-up Time	t _{CDS}	100	--	--	ns
C/D Hold Time	t _{CDH}	10	--	--	ns
CE, RD, WR Pulse Width	T _{CDS,tRD,tWR}	80	--	--	ns
Data Set-Up Time	t _{DS}	80	--	--	ns
Data Hold Time	t _{DH}	40	--	--	ns
Access Time	t _{ACC}	--	--	150	ns
Output Hold Time	t _{OH}	10	--	50	ns

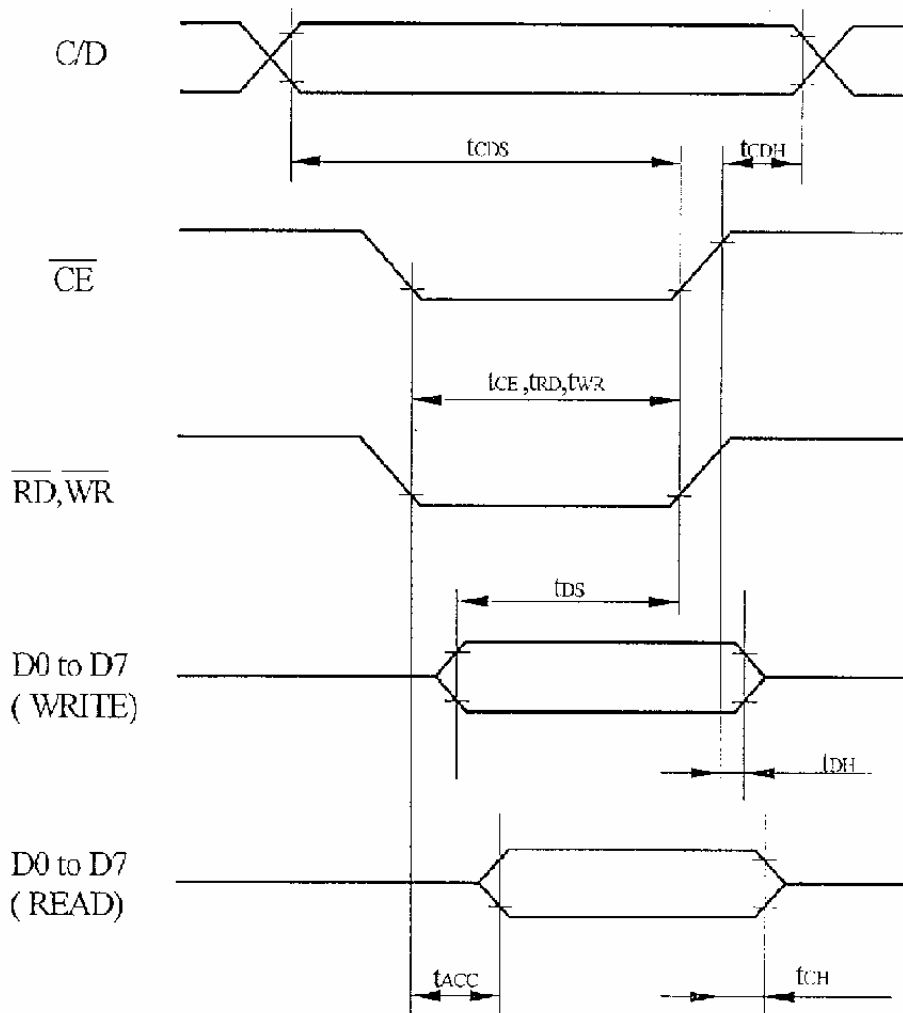



MODEL NO : ASI-B-24012BS-HE-_WD/X

12. QUALITY ASSURANCE

No.	Defect	Judgement Criterion	Partition
1	Spots	<p>A)Clear</p> <p>___Size:d mm ___ Acceptable Qty in active area</p> <p>$d \leq 0.1$ Disregard</p> <p>$0.1 < d \leq 0.2$ 6</p> <p>$0.2 < d \leq 0.3$ 2</p> <p>$0.3 < d$ 0</p> <p>Note:Including pin holes and defective dots which must be within one pixel size.</p> <p>B)Unclear</p> <p>___Size:d mm ___ Acceptable Qty in active area</p> <p>$d \leq 0.2$ Disregard</p> <p>$0.2 < d \leq 0.5$ 6</p> <p>$0.5 < d \leq 0.7$ 2</p> <p>$0.7 < d$ 0</p>	Minor
2	Bubbles in Polarizer	<p>___Size:d mm ___ Acceptable Qty in active area</p> <p>$d \leq 0.3$ Disregard</p> <p>$0.3 < d \leq 1.0$ 3</p> <p>$1.0 < d \leq 1.5$ 1</p> <p>$1.5 < d$ 0</p>	Minor
3	Scratch	In accordance with spots cosmetic criteria. When the light reflects on the panel surface, the scratches are not to be remarkable.	Minor
4	Allowable Density	Above defects should be separated more than 30mm each other.	Minor
5	Coloration	<p>Not to be noticeable coloration in the viewing area of the LCD panels.</p> <p>Back-light type should be judged with back-light on state only.</p>	Minor



MODEL NO : ASI-B-24012BS-HE-_WD/X

13. RELIABILITY

Environmental Test				
No.	Test Item	Content of Test	Test Condition	Applicable Standard
1	High Temperature storage	Endurance test applying the high storage temperature for a long time.	60°C 200hrs	—
2	Low Temperature storage	Endurance test applying the high storage temperature for a long time.	-10°C 200hrs	—
3	High Temperature Operation	Endurance test applying the electric stress (Voltage & Current) and the thermal stress to the element for a long time.	50°C 200hrs	—
4	Low Temperature Operation	Endurance test applying the electric stress under low temperature for a long time.	0°C 200hrs	—
5	High Temperature/ Humidity Storage	Endurance test applying the high temperature and high humidity storage for a long time.	70°C,90%RH 96hrs	—
6	High Temperature/ Humidity Operation	Endurance test applying the electric stress (Voltage & Current) and temperature / humidity stress to the element for a long time.	40°C,90%RH 96hrs	—
7	Temperature Cycle	Endurance test applying the low and high temperature cycle. -10°C 25°C 60°C ←—————→ 30min 5min 30min 1 cycle	-10°C/60°C 10 cycles	—
Mechanical Test				
8	Vibration test	Endurance test applying the vibration during transportation and using.	10~22Hz→1.5mmp-p 22~500Hz→1.5G Total 0.5hrs	—
9	Shock test	Constructional and mechanical endurance test applying the shock during transportation.	50G Half sign wave 11 msec 3 times of each direction	—
10	Atmospheric pressure test	Endurance test applying the atmospheric pressure during transportation by air.	115mbar 40hrs	—
Others				
11	Static electricity test	Endurance test applying the electric stress to the terminal.	VS=800V,RS=1.5kΩ CS=100pF 1 time	—

***Supply voltage for logic system=5V. Supply voltage for LCD system = Operating voltage at 25°C