



# ALL SHORE INDUSTRIES, INC.

## SPECIFICATION FOR LIQUID CRYSTAL DISPLAY MODULE

**MODULE #: ASI-B-1286GS-DB-\_WD/X**

<b>Item</b>	<b>Dimension</b>	<b>Unit</b>
Number of Characters	128 x 64 Dots	-
Module dimension	75.0 x 52.7 x 7.4(MAX)	mm
View area	60.0 x 32.6	mm
Active area	55.0 x 27.48	mm
Dot size	0.39 x 0.39	mm
Dot pitch	0.43 x 0.43	mm
LCD type	STN Positive, Transflective ,Gray	
Duty	1/64	
View direction	6 or 12 o'clock	
Backlight Type	EL, White	



**MODEL NO : ASI-B-1286GS-DB-\_WD/X**

# Contents

1. Precautions in use of LCD Modules
2. General Specification
3. Absolute Maximum Ratings
4. Electrical Characteristics
5. Optical Characteristics
6. Interface Pin Function
7. Contour Drawing & Block Diagram
8. Display control instruction
9. Timing Characteristics
10. Quality Assurance
11. Reliability
12. Backlight Information



MODEL NO : ASI-B-1286GS-DB-\_WD/X

**LCD MODULE PART NUMBERING SYSTEM**

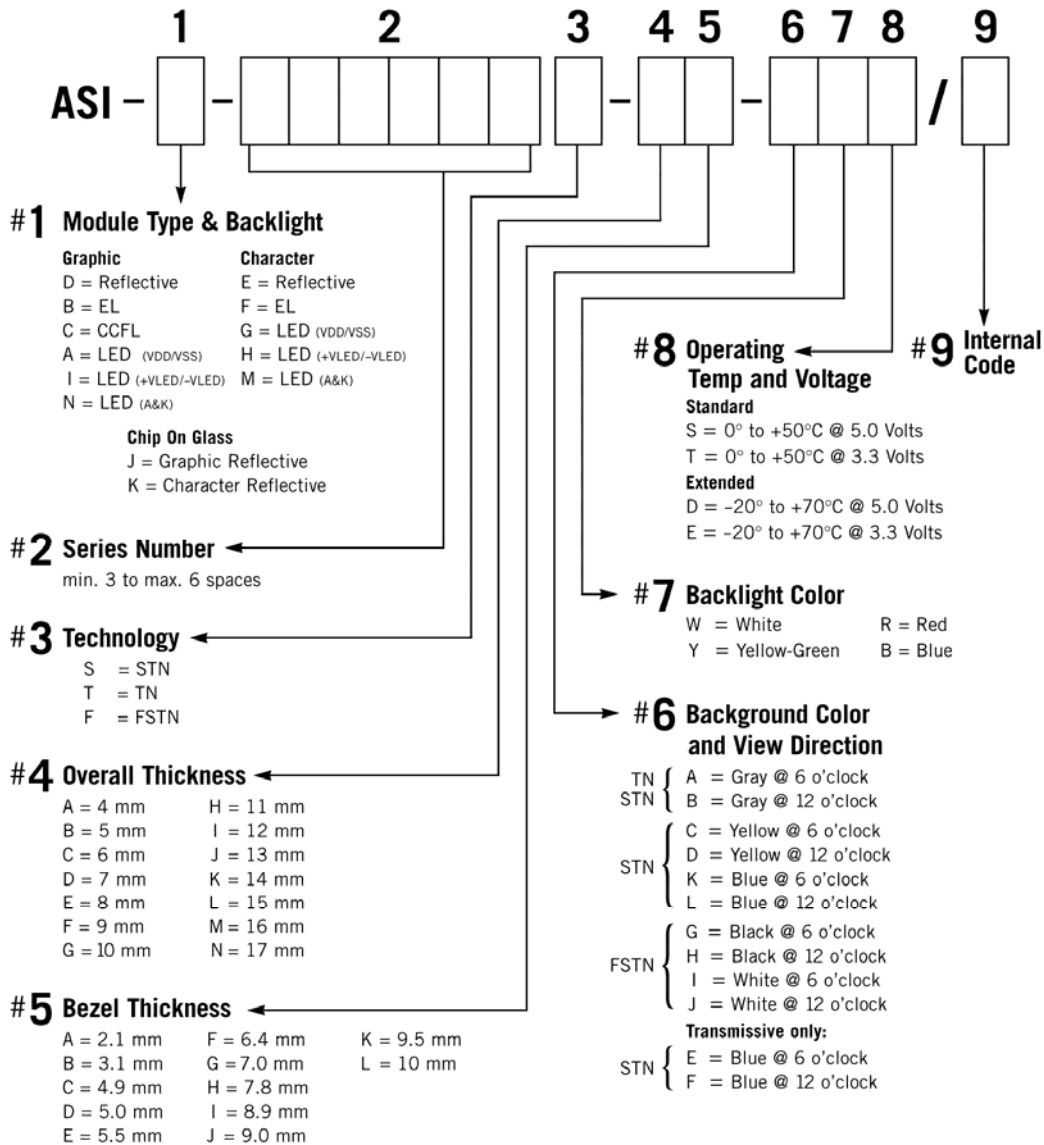

NOTE: Some options may not be available in specific modules. Please contact your Sales Representative to check availability.



## MODEL NO : ASI-B-1286GS-DB-\_WD/X

### 1. Precautions in use of LCD Modules

- (1) Avoid applying excessive shocks to the module or making any alterations or modifications to it.
- (2) Don't make extra holes on the printed circuit board, modify its shape or change the components of LCD module.
- (3) Don't disassemble the LCM.
- (4) Don't operate it above the absolute maximum rating.
- (5) Don't drop, bend or twist LCM.
- (6) Soldering: only to the I/O terminals.
- (7) Storage: please storage in anti-static electricity container and clean environment.

### 2. General Specification

Item	Dimension	Unit
Number of Characters	128 x 64 Dots	-
Module dimension	75.0 x 52.7 x 7.4(MAX)	mm
View area	60.0 x 32.6	mm
Active area	55.0 x 27.48	mm
Dot size	0.39 x 0.39	mm
Dot pitch	0.43 x 0.43	mm
LCD type	STN Positive, Transflective ,Gray	
Duty	1/64	
View direction	6 or 12 o'clock	
Backlight Type	EL, White	



## MODEL NO : ASI-B-1286GS-DB-\_WD/X

### 3. Absolute Maximum Ratings

Item	Symbol	Min	Typ	Max	Unit
Operating Temperature	$T_{OP}$	-20	-	+70	°C
Storage Temperature	$T_{ST}$	-30	-	+80	°C
Input Voltage	$V_I$	0	-	$V_{DD}$	V
Supply Voltage For Logic	$V_{DD}$	0	-	6.7	V
Supply Voltage For LCD	$V_{DD}-V_{LCD}$	0	-	16.7	V

### 4. Electrical Characteristics

Item	Symbol	Condition	Min	Typ	Max	Unit
Supply Voltage For Logic	$V_{DD}-V_{SS}$	-	4.75	5.0	5.25	V
Supply Voltage For LCD	$V_{DD}-V_0$	$T_a=-20^\circ$	-	-	9.5	V
		$T_a=25^\circ$	-	8.5	-	V
		$T_a=+70^\circ$	7.5	-	-	V
Input High Volt.	$V_{IH}$	-	$0.7V_{DD}$	-	$V_{DD}$	V
Input Low Volt.	$V_{IL}$	-	0	-	$0.3V_{DD}$	V
Output High Volt.	$V_{OH}$	-	2.4	-	-	V
Output Low Volt.	$V_{OL}$	-	-	-	0.4	V
Supply Current	$I_{DD}$	-	-	7.5	-	mA

**MODEL NO : ASI-B-1286GS-DB-\_WD/X**

**5.Optical Characteristics**

Item	Symbol	Condition	Min	Typ	Max	Unit
View Angle	(V) $\theta$	$CR \geq 2$	10	-	105	deg
	(H) $\phi$	$CR \geq 2$	-30	-	30	deg
Contrast Ratio	CR	-	-	3	-	-
Response Time	T rise	-	-	200	300	ms
	T fall	-	-	200	300	ms

**Definition of Operation Voltage (Vop)**

**Definition of Response Time ( Tr , Tf )**

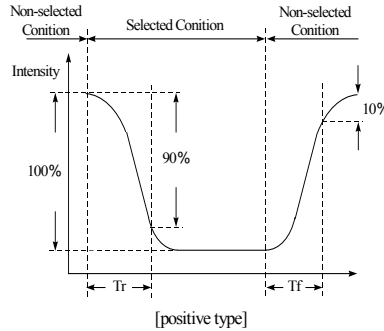
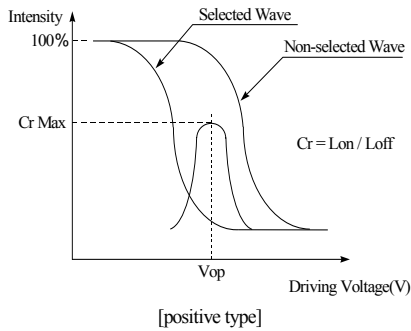

**Conditions :**

Operating Voltage : Vop

Viewing Angle( $\theta$  ,  $\phi$ ) :  $0^\circ$  ,  $0^\circ$

Frame Frequency : 64 HZ

Driving Waveform : 1/N duty , 1/a bias

**Definition of viewing angle(CR 2)**

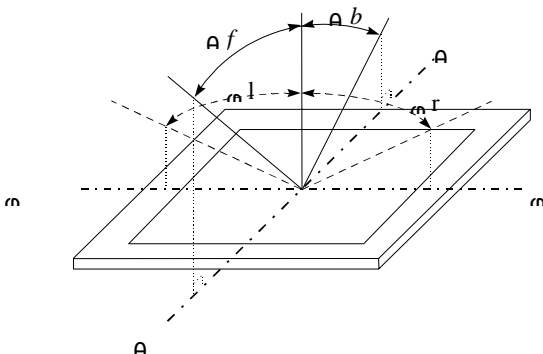



**MODEL NO : ASI-B-1286GS-DB-\_WD/X**

## 6. Interface Description

Pin No.	Symbol	Level	Description
1	VDD	5.0V	Supply voltage for logic
2	V <sub>SS</sub>	0V	Ground
3	V <sub>o</sub>	(Variable)	Operating voltage for LCD
4	DB0	H/L	Data bit 0
5	DB1	H/L	Data bit 1
6	DB2	H/L	Data bit 2
7	DB3	H/L	Data bit 3
8	DB4	H/L	Data bit 4
9	DB5	H/L	Data bit 5
10	DB6	H/L	Data bit 6
11	DB7	H/L	Data bit 7
12	CS1	L	Select Column 1~ Column 64
13	CS2	L	Select Column 65~ Column 128
14	RST	L	Reset signal
15	R/W	H/L	H: Read (MPU←Module) , L: Write (MPU→Module)
16	D/I	H/L	H: Data , L : Instruction
17	E	H	Enable signal
18	V <sub>ee</sub>	-	Negative Voltage output
19	A	-	N/C
20	K	-	N/C



MODEL NO : ASI-B-1286GS-DB-\_WD/X

7. Contour Drawing & Block Diagram

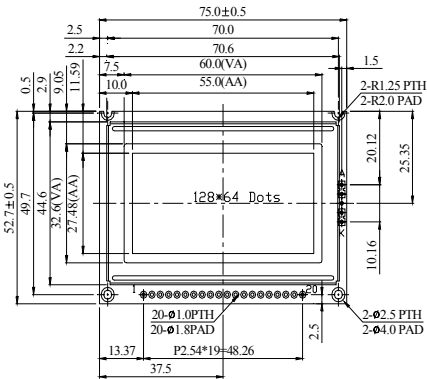

EL or NO B/L

PIN NO	SYMBOL
1	Vdd
2	Vss
3	Vo
4	DB0
5	DB1
6	DB2
7	DB3
8	DB4
9	DB5
10	DB6
11	DB7
12	CS1
13	CS2
14	R/W
15	D/I
16	E
17	Vee
18	A
19	K
20	K

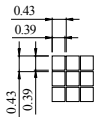

DOT SIZE

The non-specified tolerance of dimension is ±0.3mm.

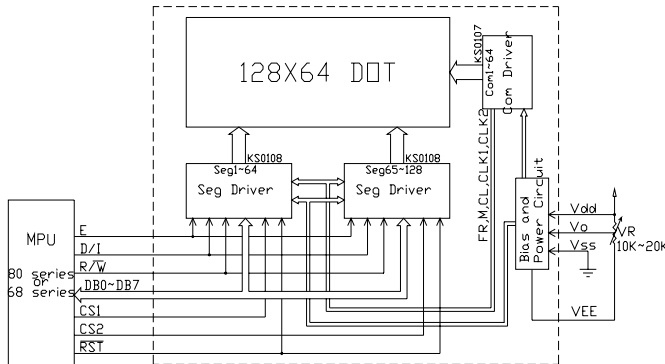

EL B/L should drive directly from A.K .

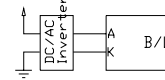

External contrast adjustment.



**MODEL NO : ASI-B-1286GS-DB-\_WD/X**

## 8. Timing Characteristics

MPU Interface

(T=25°C, VDD=+5.0V±0.5)

<b>Characteristic</b>	<b>Symbol</b>	<b>Min</b>	<b>Typ</b>	<b>Max</b>	<b>Unit</b>
E cycle	t <sub>cyc</sub>	1000	-	-	ns
E high level width	t <sub>whE</sub>	450	-	-	ns
E low level width	t <sub>wlE</sub>	450	-	-	ns
E rise time	t <sub>r</sub>	-	-	25	ns
E fall time	t <sub>f</sub>	-	-	25	ns
Address set-up time	t <sub>as</sub>	140	-	-	ns
Address hold time	t <sub>ah</sub>	10	-	-	ns
Data set-up time	t <sub>dsw</sub>	200	-	-	ns
Data delay time	t <sub>ddr</sub>	-	-	320	ns
Data hold time (write)	t <sub>dhw</sub>	10	-	-	ns
Data hold time (read)	t <sub>dhr</sub>	20	-	-	ns



MODEL NO : ASI-B-1286GS-DB-\_WD/X

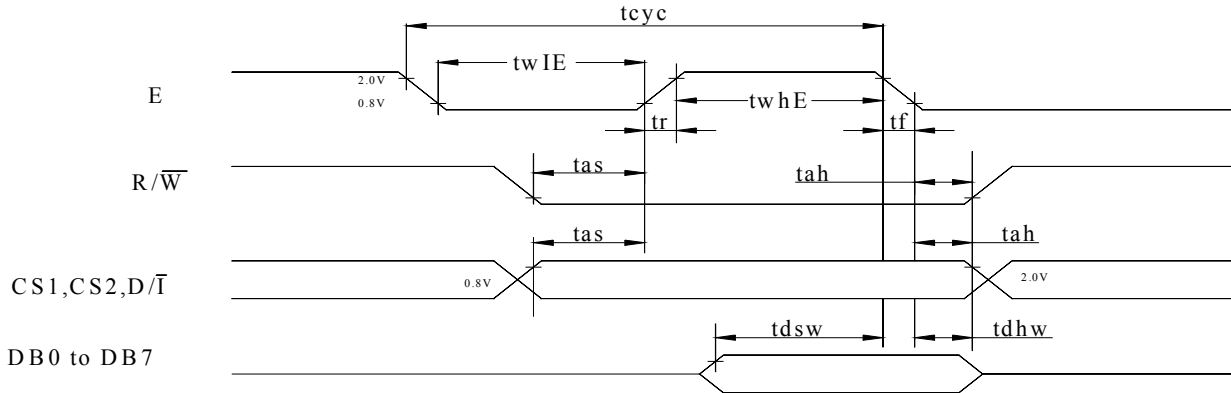

MPU Write Timing

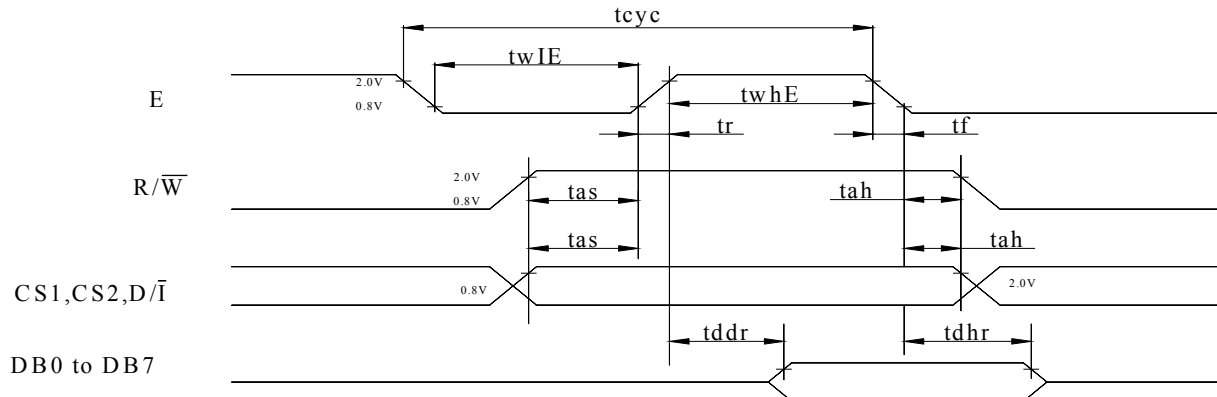

MPU Read Timing



## MODEL NO : ASI-B-1286GS-DB-\_WD/X

### 9. Display Control Instruction

The display control instructions control the internal state of the KS0108B. Instruction is received from MPU to KS0108B for the display control. The following table shows various instructions

Instruction	D/I	R/W	DB7	DB6	DB5	DB4	DB3	DB2	DB1	DB0	Function
Display ON/OFF	0	0	0	0	1	1	1	1	1	0/1	Controls the display on or off. Internal status and display RAM data are not affected. 0:OFF, 1:ON
Set Address	0	0	0	1	Y address (0~63)					Sets the Y address in the Y address counter.	
Set Page (X address)	0	0	1	0	1	1	1	Page (0 ~7)			Sets the X address at the X address register.
Display Start Line	0	0	1	1	Display start line(0~63)					Indicates the display data RAM displayed at the top of the screen.	
Status Read	0	1	B U S Y	0	ON/ OFF	R E S E T	0	0	0	0	Read status. BUSY 0:Ready 1:In operation ON/OFF 0:Display ON 1:Display OFF RESET 0:Normal 1:Reset
Write Display Data	1	0	Display Data								Writes data (DB0:7) into display data RAM. After writing instruction, Y address is increased by 1 automatically.
Read Display Data	1	1	Display Data								Reads data (DB0:7) from display data RAM to the data bus.



## MODEL NO : ASI-B-1286GS-DB-\_WD/X

### 10. Detailed Explanation

#### Display On/Off

R/W	D/I	DB7	DB6	DB5	DB4	DB3	DB2	DB1	DB0
0	0	0	0	1	1	1	1	1	D

The display data appears when D is 1 and disappears when D is 0. Though the data is not on the screen with D = 0, it remains in the display data RAM. Therefore, you can make it appear by changing D = 0 into D = 1.

#### Display Start Line

R/W	D/I	DB7	DB6	DB5	DB4	DB3	DB2	DB1	DB0
0	0	1	1	A	A	A	A	A	A

Z address AAAAAA ( binary ) of the display data RAM is set in the display start line register and displayed at the top of the screen. Figure 2. shows examples of display ( 1/64 duty cycle ) when the start line = 0-3. When the display duty cycle is 1/64 or more ( ex. 1/32, 1/24 etc. ), the data of total line number of LCD screen, from the line specified by display start line instruction, is displayed

#### Set Page ( X Address )

R/W	D/I	DB7	DB6	DB5	DB4	DB3	DB2	DB1	DB0
0	0	1	0	1	1	1	A	A	A

X address AAA ( binary ) of the display data RAM is set in the X address register. After that, writing or reading to or from MPU is executed in this specified page until the next page is set. See Figure 1.



## MODEL NO : ASI-B-1286GS-DB-\_WD/X

### Set Y Address

R/W	D/I	DB7	DB6	DB5	DB4	DB3	DB2	DB1	DB0
0	0	0	1	A	A	A	A	A	A

Y address AAAAAA ( binary ) of the display data RAM is set in the Y address counter. After that, Y address counter is increased by 1 every time the data is written or read to or from MPU.

### Status Read

R/W	D/I	DB7	DB6	DB5	DB4	DB3	DB2	DB1	DB0
0	0	Busy	0	On/Off	RESET	0	0	0	0

### Busy

When busy is 1, the LSI is executing internal operations. No instruction are accepted while busy is 1, so you should make sure that busy is 0 before writing the next instruction.

### ON/OFF

Shows the liquid crystal display condition: on condition or off condition.

When on/off is 1, the display is in off condition.

When on/off is 0, the display is in on condition

### RESET

RESET = 1 shows that the system is being initialized. In this condition, no instructions except status read can be accepted.

RESET = 0 shows that initializing has system is in the usual operation condition.

### Write Display Data

R/W	D/I	DB7	DB6	DB5	DB4	DB3	DB2	DB1	DB0
0	0	D	D	D	D	D	D	D	D

Writes 8-bit data DDDDDDDD ( binary ) into the display data RAM. The Y address is increased by 1 automatically.



**MODEL NO : ASI-B-1286GS-DB-\_WD/X**

**Read Display Data**

R/W	D/I	DB7	DB6	DB5	DB4	DB3	DB2	DB1	DB0
0	0	D	D	D	D	1	D	D	D

Reads out 8-bit data DDDDDDDD ( binary ) from the display data RAM. Then Y address is increased by 1 automatically.

One dummy read is necessary right after the address setting. For details, refer to the explanation of output register in “Function of Each Block”.

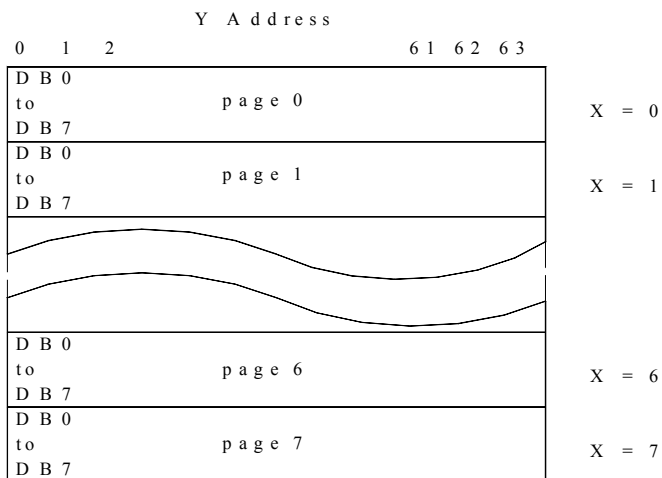
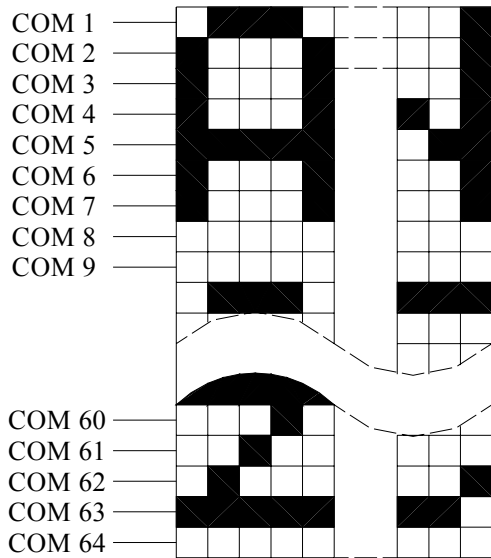

Figure 1.



MODEL NO : ASI-B-1286GS-DB-\_WD/X



Start line = 0

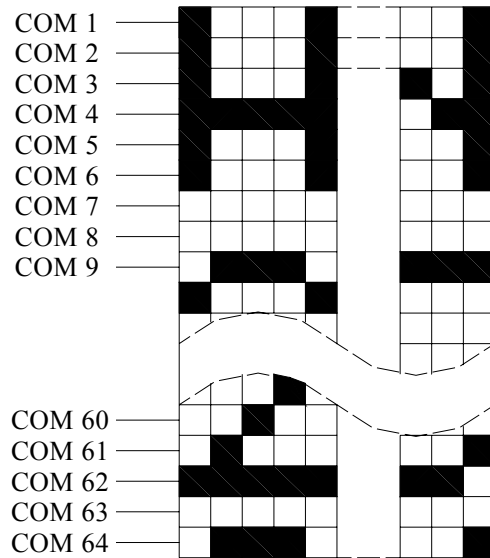

Start line = 1

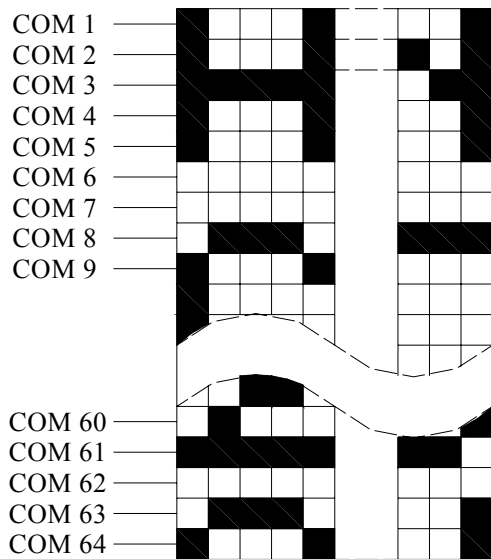

Start line = 3

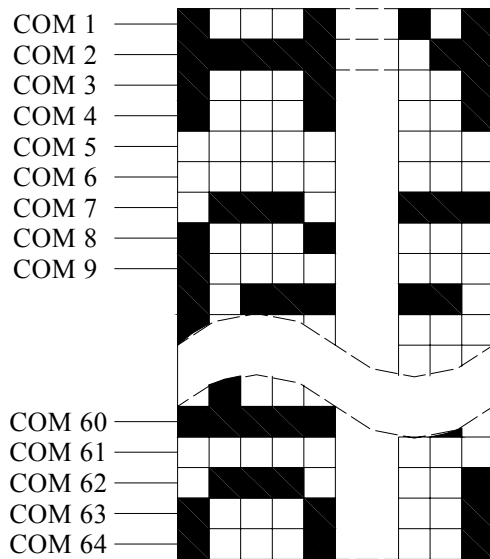

Start line = 4



**MODEL NO : ASI-B-1286GS-DB-\_WD/X**

## 11. Quality Assurance

### Screen Cosmetic Criteria

No.	Defect	Judgment Criterion	Partition
1	Spots	<p align="center">A)Clear</p> <p align="center"><u>Size: d mm</u>    <u>Acceptable Qty in active area</u></p> <p align="center">d ≤ 0.1            Disregard</p> <p align="center">0.1 &lt; d ≤ 0.2            6</p> <p align="center">0.2 &lt; d ≤ 0.3            2</p> <p align="center">0.3 &lt; d                    0</p> <p align="center">Note: Including pin holes and defective dots which must be within one pixel size.</p> <p align="center">B)Unclear</p> <p align="center"><u>Size: d mm</u>    <u>Acceptable Qty in active area</u></p> <p align="center">d ≤ 0.2            Disregard</p> <p align="center">0.2 &lt; d ≤ 0.5            6</p> <p align="center">0.5 &lt; d ≤ 0.7            2</p> <p align="center">0.7 &lt; d                    0</p>	Minor
2	Bubbles in Polarize	<p align="center"><u>Size: d mm</u>    <u>Acceptable Qty in active area</u></p> <p align="center">d ≤ 0.3            Disregard</p> <p align="center">0.3 &lt; d ≤ 1.0            3</p> <p align="center">1.0 &lt; d ≤ 1.5            1</p> <p align="center">1.5 &lt; d                    0</p>	Minor
3	Scratch	In accordance with spots cosmetic criteria. When the light reflects on the panel surface, the scratches are not to be remarkable.	Minor
4	Allowable Density	Above defects should be separated more than 30mm each other.	Minor
5	Coloration	Not to be noticeable coloration in the viewing area of the LCD panels. Back-light type should be judged with back-light on state only.	Minor



## MODEL NO : ASI-B-1286GS-DB-\_WD/X

### 12. Reliability

#### Content of Reliability Test

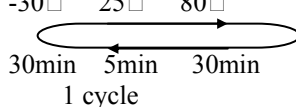
Environmental Test			
Test Item	Content of Test	Test Condition	Applicable Standard
High Temperature storage	Endurance test applying the high storage temperature for a long time.	80□ 200hrs	—
Low Temperature storage	Endurance test applying the high storage temperature for a long time.	-30□ 200hrs	—
High Temperature Operation	Endurance test applying the electric stress (Voltage & Current) and the thermal stress to the element for a long time.	70□ 200hrs	—
Low Temperature Operation	Endurance test applying the electric stress under low temperature for a long time.	-20□ 200hrs	—
High Temperature/ Humidity Storage	Endurance test applying the high temperature and high humidity storage for a long time.	80□,90%RH 96hrs	—
High Temperature/ Humidity Operation	Endurance test applying the electric stress (Voltage & Current) and temperature / humidity stress to the element for a long time.	70□,90%RH 96hrs	—
Temperature Cycle	Endurance test applying the low and high temperature cycle. 	-30□/80□ 10 cycles	—
Mechanical Test			
Vibration test	Endurance test applying the vibration during transportation and using 3 times of each direction	10~22Hz→1.5mmp-p; 22~500Hz→1.5G; Total 0.5hrs	—
Shock test	Constructional and mechanical endurance test applying the shock during transportation.	50G Half sign; wave 11 m sec 3 times of each direction	—
Atmospheric pressure test	Endurance test applying the atmospheric pressure during transportation by air.	115mbar; 40hrs	—
Others			
Static electricity test	Endurance test applying the electric stress to the terminal.	VS=800V,RS=1.5kΩ CS=100pF; 1 time	—

\*\*\*Supply voltage for logic system=5V. Supply voltage for LCD system =Operating voltage at 25□



**MODEL NO : ASI-B-1286GS-DB-\_WD/X**

## 14. Backlight Information

### Specification

PARAMETER	SYMBOL	MIN	TYP	MAX	UNIT	TEST CONDITION
Drive Voltage	Vmax	—	110	170	Vrms	25°C
Drive Wave	Fmax	-	400	1000	Hz	25°C
Brightness	-	48	60	-	cd/m <sup>2</sup>	110V/400Hz
Power Consumption	-	-	48.9	-	mW	110V/400Hz
Chromatism	X	-	0.330	-	-	110V/400Hz
	Y	-	0.365	-	-	
Life time	-	5000hrs				110V/400Hz
Color	-	White				Light on 110V/400Hz