



All Shore Industries, Inc.

P/N ASI-J-14432AF--P-ID/A

YC Jao	B	YC Jao	Michael Chen	Kevin Lin

Approved By:

TABLE OF CONTENTS

- 1. GENERAL DESCRIPTION**
- 2. MECHANICAL DIMENSION**
- 3. ABSOLUTE MAXIMUM RATINGS**
- 4. ELECTRICAL CHARACTERISTICS**
- 5. INTERFACE PIN CONNECTIONS**
- 6. BLOCK DIAGRAM OF LCM**
- 7. ELECTRO-OPTICAL CHARACTERISTICS**
- 8. RELIABILITY**
- 9. USING LCD MODULES**
- 10. INSPECTION STANDARD OF LCM**
- 11.Packing

1. GENERAL DESCRIPTION

LCD Type	FSTN POSITIVE REFLECTIVE
Display Format	144*32DOTS
Input Data	parallel data input from MPU
Driving Method	1/33DUTY, 1/5BIAS
Viewing Direction	6: 00 O'CLOCK
Driver IC	RA8816
Module Size(W*H*T)	86*26.15/33.7MAX
Viewing Area (W*H)	83.6*23.75
Dot Pitch (W*H)	0.56*0.65
Dot Size (W*H)	0.51*0.6
Active Area (W*H)	80.59*20.75
Others	ROHS

2. MECHANICAL DIMENSION

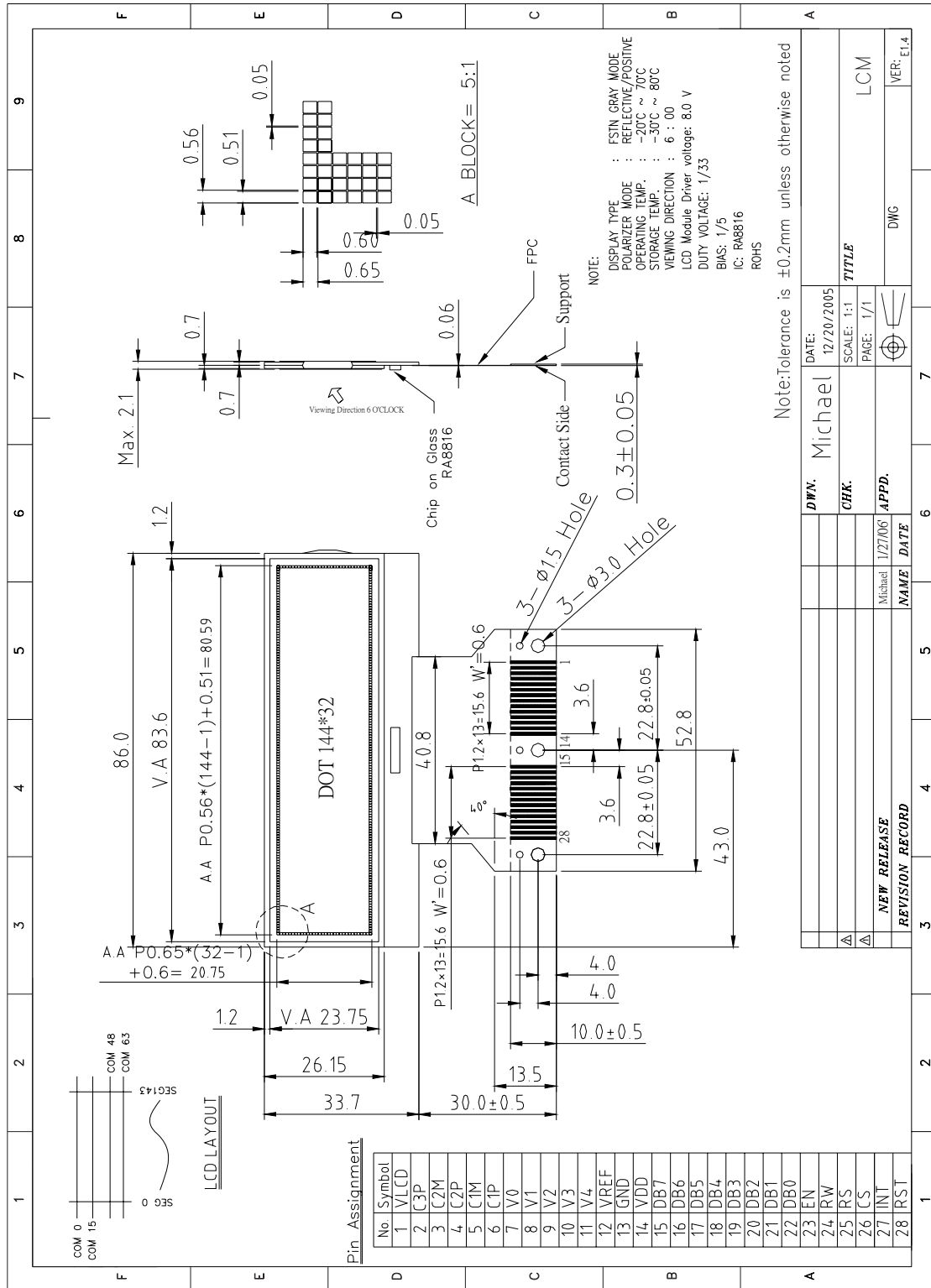

3. ABSOLUTE MAXIMUM RATINGS

Item	Symbol	MIN	Max	Unit
Supply Voltage	VDD	2.7	3.8	V
	VLCD	2.7	12.0	V
Input Voltage	Vin	0.3	VDD+0.3	V
Operating temperature	Topr	-20	70	°C
Storage temperature	Tstr	-30	80	°C

4. ELECTRICAL CHARACTERISTICS

Item		Symbol	Condition	Min.	Typ.	Max.	Unit
Suppl Voltage	Logic	V _{DD}	V _{DD} -GND	3.1	3.3	3.5	V
	LCD	V _{LCD}	-	7.8	8.0	8.2	V
Input Voltage	H level	V _{IH}	-	0.8VDD	--	VDD	V
	L level	V _{IL}		VSS	--	0.2VDD	
Current Consumption (without backlight)		I _{DD}	-			1	mA

5. INTERFACE PIN CONNECTIONS

PIN NO	SYMBOL	FUNCTIONS
1	VLCD	Voltage converter input / output pin Connect this pin to Vss through capacitor.
2	C3P	Capacitor 3 positive connection pin for voltage converter
3	C2M	Capacitor 2 negative connection pin for voltage converter
4	C2P	Capacitor 2 positive connection pin for voltage converter
5	C1M	Capacitor 1 negative connection pin for voltage converter
6	C1P	Capacitor 1 positive connection pin for voltage converter
7	V0	VLCD power supply
8	V1-V4	LCD driver supply voltages The voltage determined by LCD pixel is impedance-converted by an operational amplifier for application. Voltages should have the following relationship; $V0 \geq V1 \geq V2 \geq V3 \geq V4 \geq VSS$
12	VREF	Reference voltage
13	GND	Connect to ground
14	VDD	Power supply
15-22	DB7-DB0	Input data
23	EN	enable signal
24	RW	Read or write control pin
25	RS	Register select input pin – RS = "H": DB0 to DB7 are display data – RS = "L": DB0 to DB7 are control data
26	CS	Chip select input pins
27	INT	Interrupt control pin
28	RST	Reset input pin When RESETB is "L", initialization is executed.

6. BLOCK DIAGRAM OF LCM

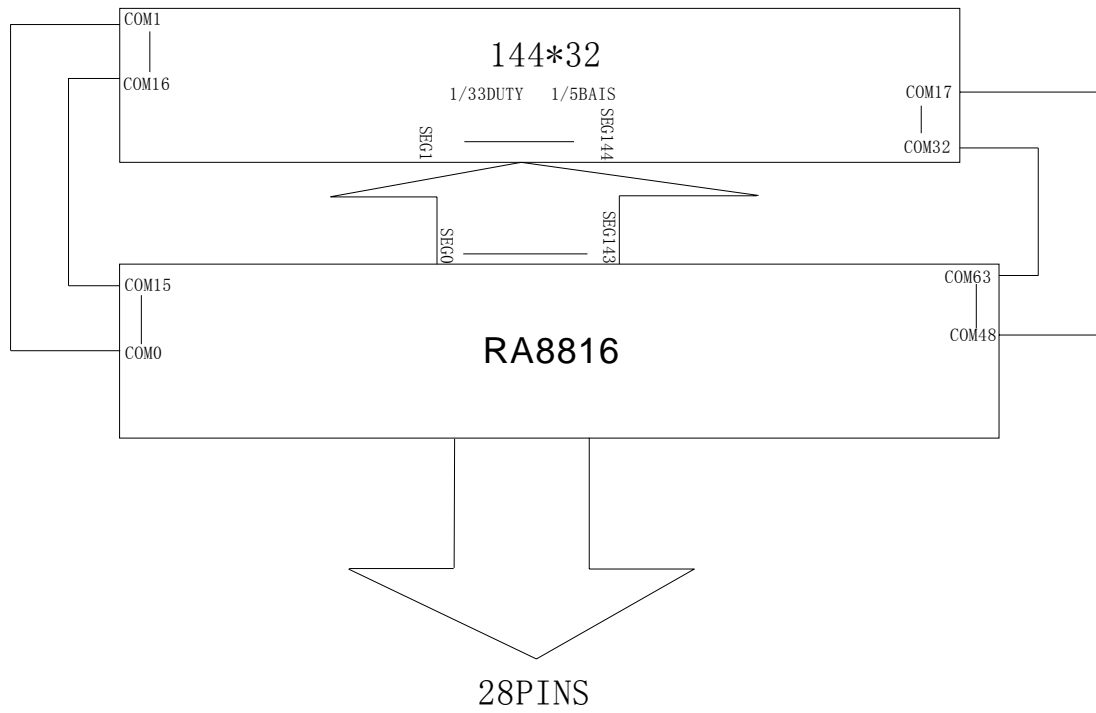

7. Electro-Optical Characteristics

Item	Symbol	Condition	Min	Typ	Max	Units
Contrast	K	$\theta=0^\circ \quad \Phi=0^\circ$	3	—	—	deg.
Viewing Angle	θ	K=3.0 θ_x	-40	—	40	deg.
		K=3.0 θ_y	-25	—	40	deg.
Response time	T_{on}	25°C	—	—	250	ms
	T_{off}	25°C	—	—	250	ms

(1). Definition of Optical Response Time

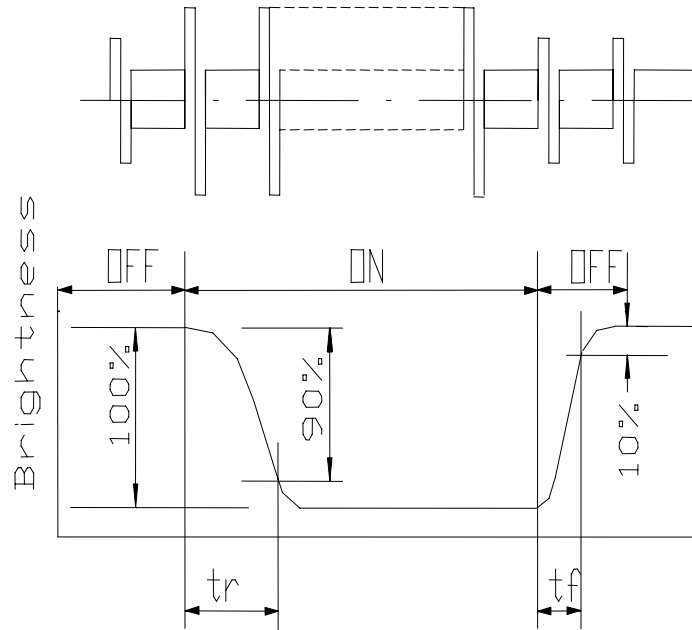

(2). Definition of Driving Voltage (V_{lcd})

$$V_{lcd} = (V_{10,ON} + V_{90,OFF}) / 2$$

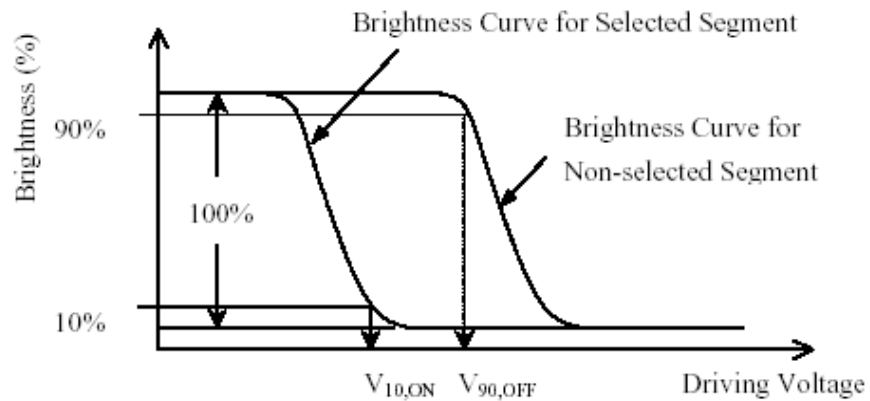

(3). Definition of Viewing Angle θ and Φ

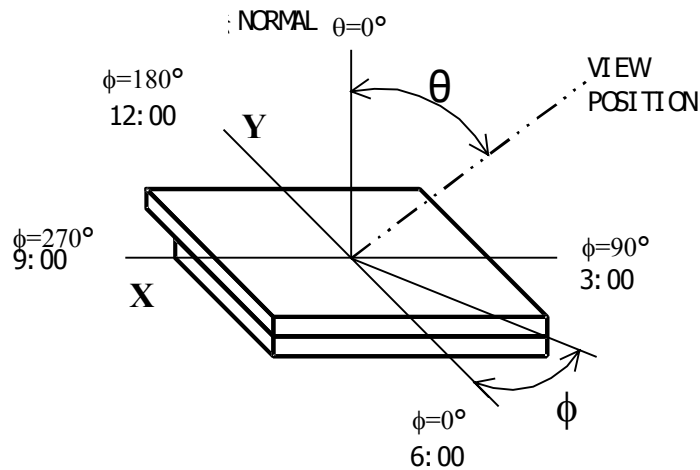

8. RELIABILITY

ITEM	CONDITIONS	CRITERIA
High temperature operation	70°C for 96 hours	
Low temperature operation	-20°C for 96 hours	
High humidity storage	40°C,90%RH for 96 hours	
High temperature storage	80°C for 96 hours	
Low temperature storage	-30°C for 96 hours	
Temperature cycling	80°C (30 min) ↓ ↑ 25°C (5 min) ↓ ↑ -30°C (30 min) CYCLES: 5	

9. USING LCD MODULES

a. LIQUID CRYSTAL DISPLAY MODULES

LCD is composed of glass and polarizer. Pay attention to the following items when handling.

1. Please keep the temperature within specified range for use and storage. Polarization degradation, bubble generation or polarizer peel-off may occur with high temperature and high humidity.
2. Do not touch, push or rub the exposed polarizer with anything harder than a HB pencil lead (glass, tweezers, etc).
3. N-hexane is recommended for cleaning the adhesives used to attach front/rear polarizer and reflectors made of organic substances, which will be damaged by chemicals such as acetone, toluene, toluene, ethanol and isopropyl alcohol.
4. When the display surface becomes dusty, wipe gently with absorbent cotton or other soft material like chamois soaked in petroleum ether. Do not scrub hard to avoid damaging the display surface.
5. Wipe off saliva or water drops immediately, contact with water over a long period of time may cause deformation or color fading.
6. Avoid contacting oil and fats.
7. Condensation on the surface and contact with terminals due to cold will damage, stain or polarizer. After products are tested at low temperature they must be warmed up in a container before coming is contacting with room temperature air.
8. Do not put or attach anything on the display area to avoid leaving marks on.
9. Do not touch the display with bare hands. This will stain the display area and degrade insulation between terminals (some cosmetics are determinate to the polarizer).
10. As glass is fragile, it tends to become or chipped during handling especially on the edges. Please avoid dropping or jarring.

All Shore Industries, Inc. P/N ASI-J-14432AF--P-ID/A

b. INSTALLING LCD MODULE

Attend to the following items when installing the LCM.

1. Cover the surface with a transparent protective plate to protect the polarizer and LC cell.
2. When assembling the LCM into other equipment, the spacer to the bit between the LCM and the fitting plate should have enough height to avoid causing stress to the module surface, refer to the individual specifications for measurements. The measurement tolerance should be ± 0.1 mm.

c. ELECTRO-STATIC DISCHARGE CONTROL

Since this module uses a CMOS LSI, the same careful attention should be paid for electrostatic discharge as for ordinary CMOS IC.

1. Make certain that you are grounded when handling LCM.
2. Before removing LCM from its packing case or incorporating it into a set, be sure the module and your body have the same electric potential.
3. When soldering the terminal of LCM, make certain the AC power source for the soldering iron does not leak.
4. When using an electric screwdriver to attach LCM, the screwdriver should be of ground potentiality to minimize as much as possible any transmission of electromagnetic waves produced sparks coming from the commutate of the motor.
5. As far as possible, make the electric potential of your work clothes and that of the workbenches to the ground potential.
6. To reduce the generation of electro-static discharge, be careful that the air in the work is not too dried. A relative humidity of 50%-60% is recommended.

d. PRECAUTIONS FOR OPERATION

1. Viewing angle varies with the change of liquid crystal driving voltage (V_o). Adjust V_o to show the best contrast.
2. Driving the LCD in the voltage above the limit will shorten its lifetime.
3. Response time is greatly delayed at temperature below the operating temperature range. However, this does not mean the LCD will be out of the order. It will recover when it returns to the specified temperature range.
4. If the display area is pushed hard during operation, the display will become abnormal. However, it will return to normal if it is turned off and then on.

10 INSPECTION STANDARD OF LCM.

AQL inspection standard

Sampling method: MIL-STD-105E, Level II, single sampling

Defect classification (Note: * is not including)

Classify	Item		Note	AQL	
Major	Display state	Short or open circuit	1	0.4	
		Flickering			
		No display			
		Wrong viewing direction			
	No-display	Flat cable or pin reverse	10		
		Wrong or missing component	11		
LC leakage		1			
Minor	Display state	Background color deviation	2	1.0	
		Black spot and dust	3	1.0	
		Line defect	4	1.0	
		Rainbow	5	1.0	
		Pin hole	6	1.0	
		Segment defect	7	1.0	
		Back-light	1,8	1.0	
		Contrast defect (dim, ghost)	2	1.0	
	Polarizer	Scratch	4	1.0	
		Bubble and foreign material	3	1.0	
	Soldering	Poor connection	9	1.0	
	Wire	Poor connection	10	1.0	
	TOTAL				1.5

Note on defect classification

All Shore Industries, Inc. P/N ASI-J-14432AF--P-ID/A

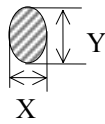
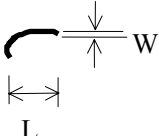
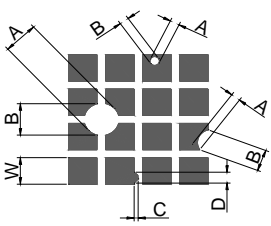
No	Item	Criterion			
1	Short or open circuit	Not allow			
	Lc Leakage				
	Flickering				
	No display				
	Wrong viewing direction				
	Wrong Back-light				
2	Contrast defect	refer to approval sample			
	Background color deviation				
3	Point defect Back spot,dust (including polarizer) $\Phi=(X+Y)/2$ 	Point Size (Unit: mm)	Acceptable Qty		
		$\Phi \leq 0.10$	Disregarded		
		$0.10 < \Phi \leq 0.20$	3		
		$0.20 < \Phi \leq 0.25$	2		
		$0.25 < \Phi \leq 0.30$	1		
		$\Phi > 0.30$	0		
4	Line defect scratch (including polarizer) 	Line (Unit: mm)		Acceptable Qty	
		L	W		
		---	$0.015 \geq W >$	Disregard	
		≤ 2.5	$0.03 \geq W > 0.015$	2	
		≤ 1.5	$0.05 \geq W > 0.03$	2	
		≤ 1.5	$0.1 \geq W > 0.05$	1	
			$W > 0.1$	Applied as point defect	
5	Rainbow	According to the limit sample			
6	Pin hole  <p>Matrix type: pin hole</p>	Size	Area $\leq 60 \text{cm}^2$	Area $> 60 \text{cm}^2$	
			Allowed number		
		$\phi \leq 0.1$	Disregarded		
		$0.10 < \phi \leq 0.15$	2	3	
		$0.15 < \phi \leq 0.2$	1	2	
		$\phi > 0.2$	0	0	

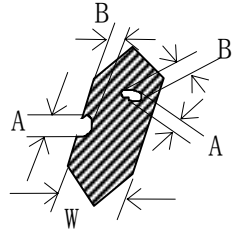
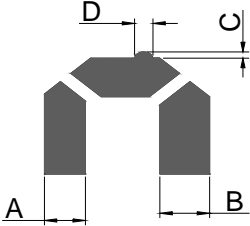
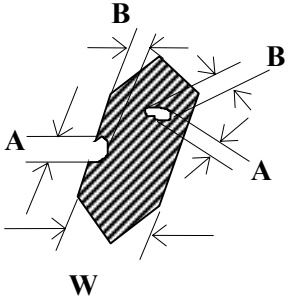
	 <p>Segment type: pin hole</p>	<p>Remark</p> <p>W: width of dot or segment A: in the horizontal direction B: in the vertical direction $\phi: (A+B)/2$</p>											
7	<p>Segment defect:</p> <p>1) Segment width defect</p> 	<p>Size (mm)</p>	<p>Allowed number</p>										
		<p>$(C+D)/2 \leq 0.10$</p>	<p>2</p>										
		<p>$0.10 < (C+D)/2 \leq 0.2$</p>	<p>1</p>										
		<p>$(C+D)/2 > 0.20$</p>	<p>Not Allowed</p>										
	<p>2) Segment pattern</p> 	<p>Remark</p> <p>A: in the horizontal direction B: in the vertical direction Segment width defect allowed standard $A - B < 0.2\text{mm}$ Does not touch other segment or matrix spot $D \leq W/3$ (W: width of dot or segment)</p> <table border="1" data-bbox="667 1267 1396 1711"> <thead> <tr> <th>POINT SIZE (Unit: mm)</th> <th>Acceptable Qty</th> </tr> </thead> <tbody> <tr> <td>$\Phi < 0.10\text{mm}$</td> <td>Disregarded</td> </tr> <tr> <td>$\Phi \leq 1/4W$</td> <td>Disregarded</td> </tr> <tr> <td>$1/4W < \Phi \leq 1/2W$</td> <td>1</td> </tr> <tr> <td>$\Phi > 1/2W$</td> <td>0</td> </tr> </tbody> </table> <p>Remark: W=SEGMENT WIDTH; $\Phi = (A+B) / 2$</p>		POINT SIZE (Unit: mm)	Acceptable Qty	$\Phi < 0.10\text{mm}$	Disregarded	$\Phi \leq 1/4W$	Disregarded	$1/4W < \Phi \leq 1/2W$	1	$\Phi > 1/2W$	0
	POINT SIZE (Unit: mm)	Acceptable Qty											
	$\Phi < 0.10\text{mm}$	Disregarded											
	$\Phi \leq 1/4W$	Disregarded											
	$1/4W < \Phi \leq 1/2W$	1											
	$\Phi > 1/2W$	0											
<p>8</p> <p>Back-light</p>	<p>1) the color of backlight should correspond its specification</p> <p>2) not allow flickering</p>												
<p>9</p> <p>Soldering</p>	<p>(1) not allow heavy dirty and solder ball on PCB(the size of dirty refer to point and dust defect)</p>												

All Shore Industries, Inc. P/N ASI-J-14432AF--P-ID/A

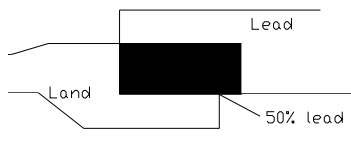
		<p>(2) over 50% of lead should be soldered on land</p>
10	Wire	<p>(1) copper wire should not be rusted</p> <p>(2) not allow crack on copper wire connection</p> <p>(3) not allow reversing the position of the flat cable</p>

11 Packing

PACKAGE MODE:

MODEL NAME: GY1403A1

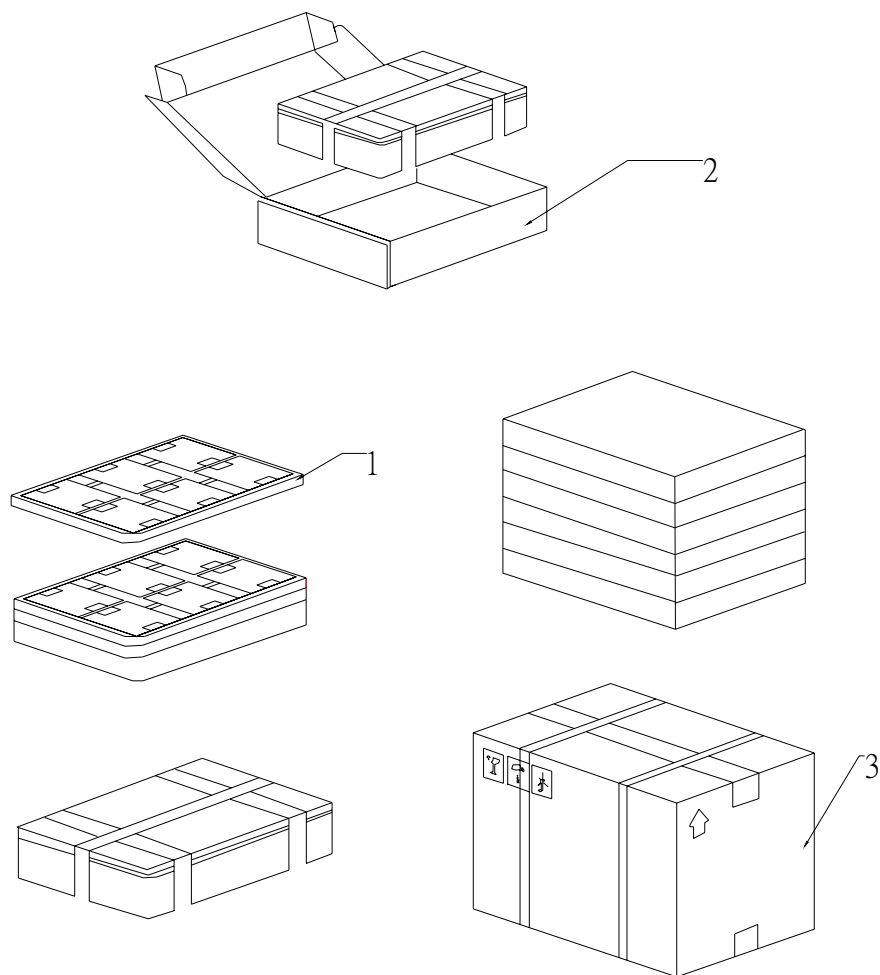

PARTS LIST					
	ITEM	SIZE(LxWxH)unit:mm	MATERIAL	Q.T.Y	NOTE
1	TRAY	390*230*9	PET	12	一盒內可放9層PVC,共計96PCS
2	INTERNAL BOXS	420*240*52	CARTON	6	一箱內可放六個小盒,共計576PCS
3	EXTERNAL BOX	435*255*345	CARTON	1	
	PRODUCT	86*63.7*2.1	---	576	